



UNIVERSITY OF
GEORGIA

Autonomous Laser Weed Control for Vidalia Onion Production

Vidalia Onion Meeting September 2025

Muneeb Elahi Malik

Graduate Research Assistant

School of Electrical & Computer Engineering

Principal Investigator

Dr. Md Sultan Mahmud

Assistant Professor of Precision Crop Protection

Sep 10, 2025

Robotic Laser Weeding

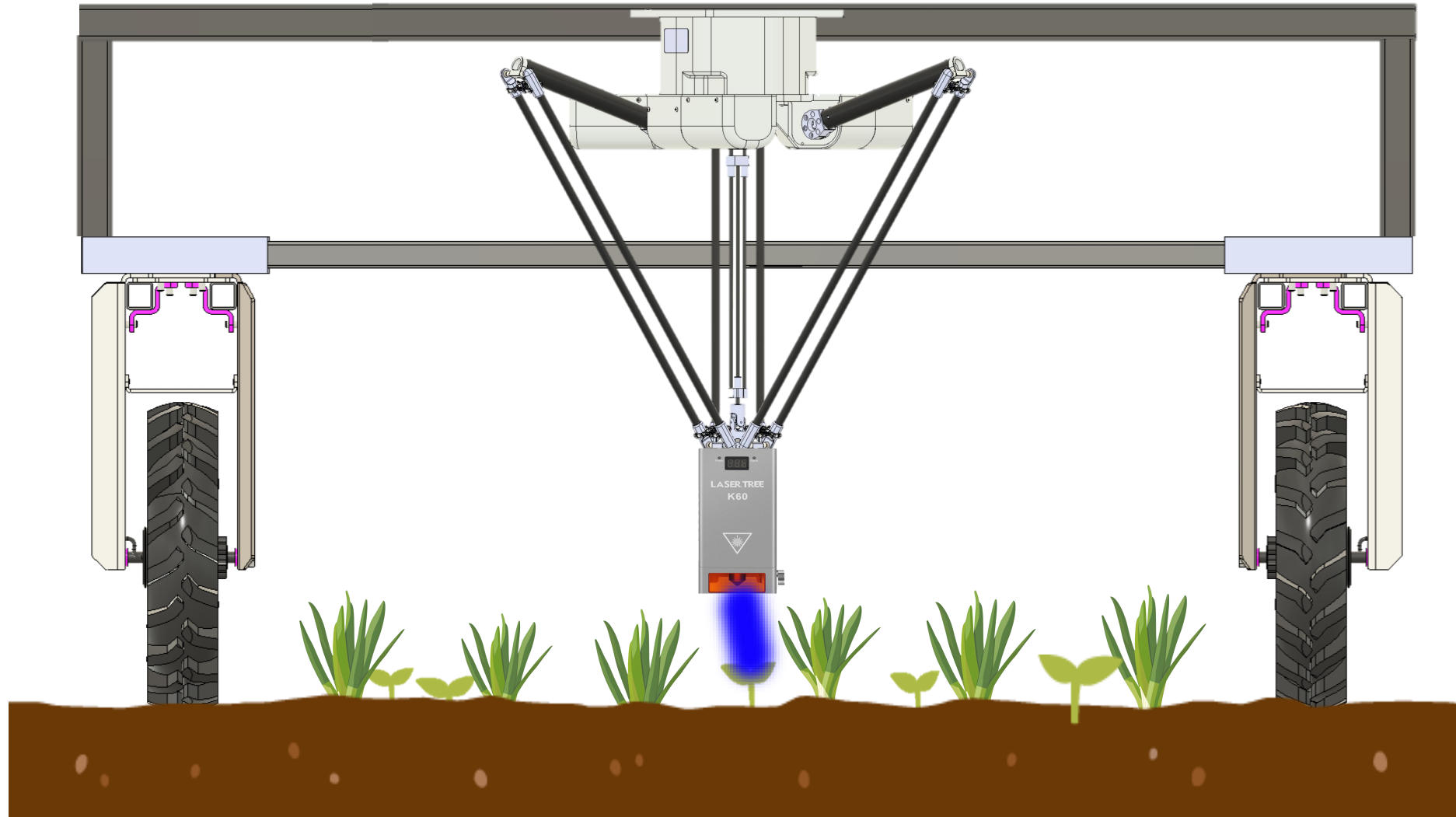

1. The Delta Robot

Fast, precise robot that moves the laser to hit weeds.

Why Delta Robot?

- Sub-millimeter accuracy
- Fastest industrial robots
- Stable movements

3 Arm
pairs

3 Stepper
Motors

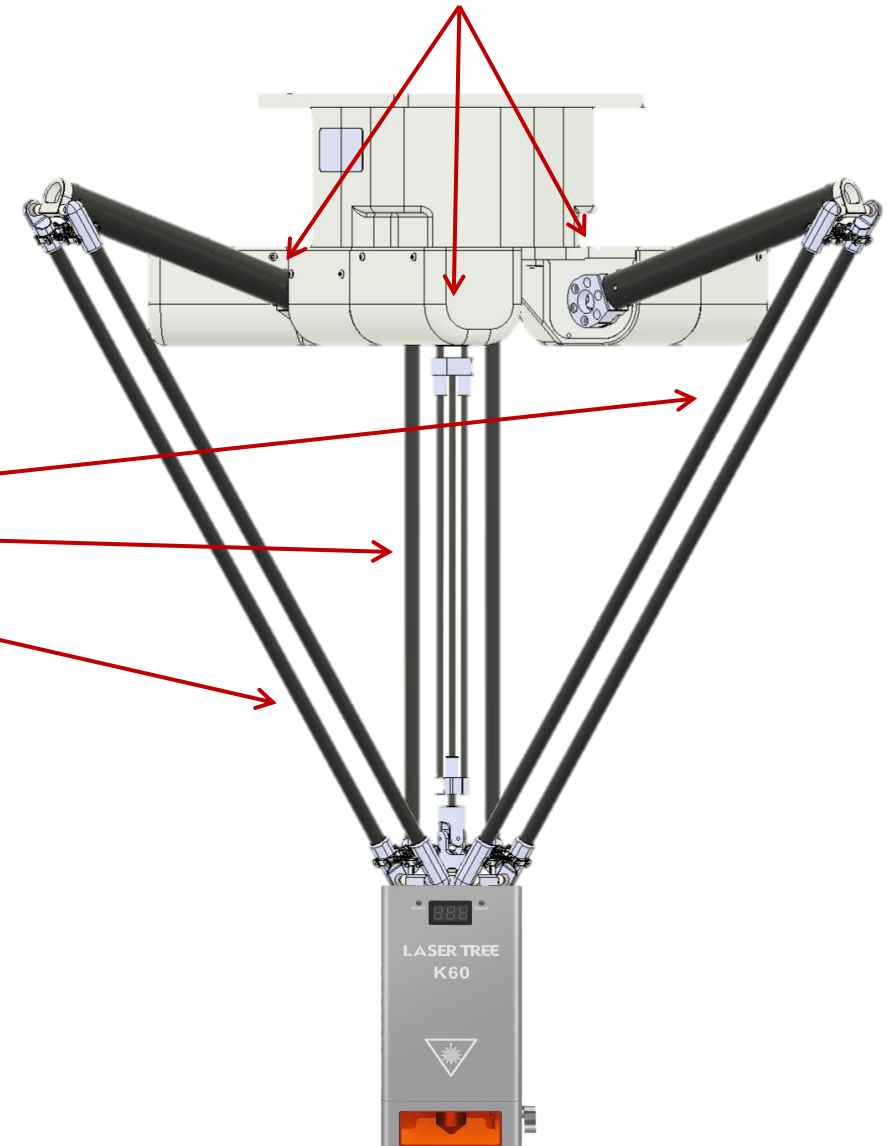

2. Diode Laser

Emits a high-power blue light that burns weeds

Why Blue light?

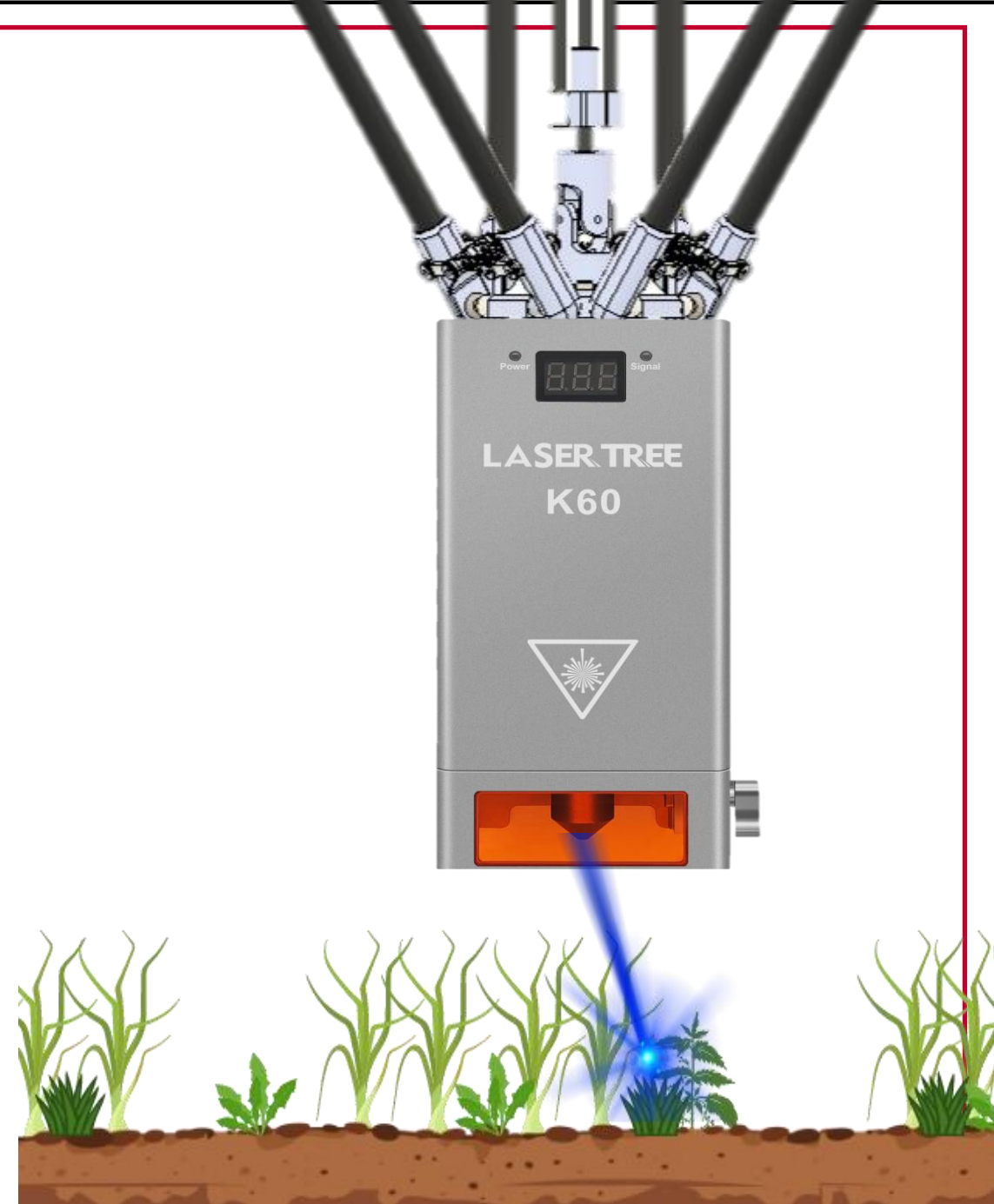
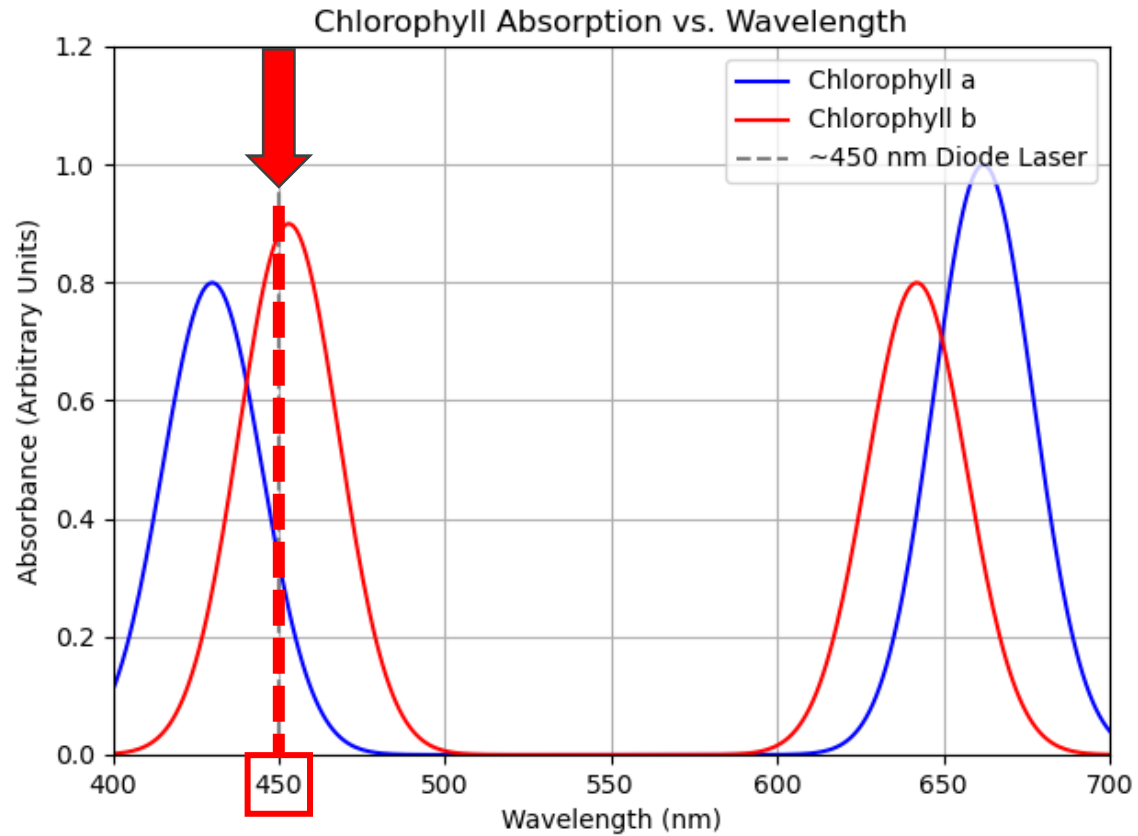

2. Diode Laser

Emits a high-power blue light that burns weeds

Why Blue light?

- Blue light (450 nm) is absorbed strongly by weeds → **fast kill**.
- Low heat spread → **onions stay safe**.
- Non-contact → cleaner, chemical-free fields.
- Efficient → Less power, air-cooled

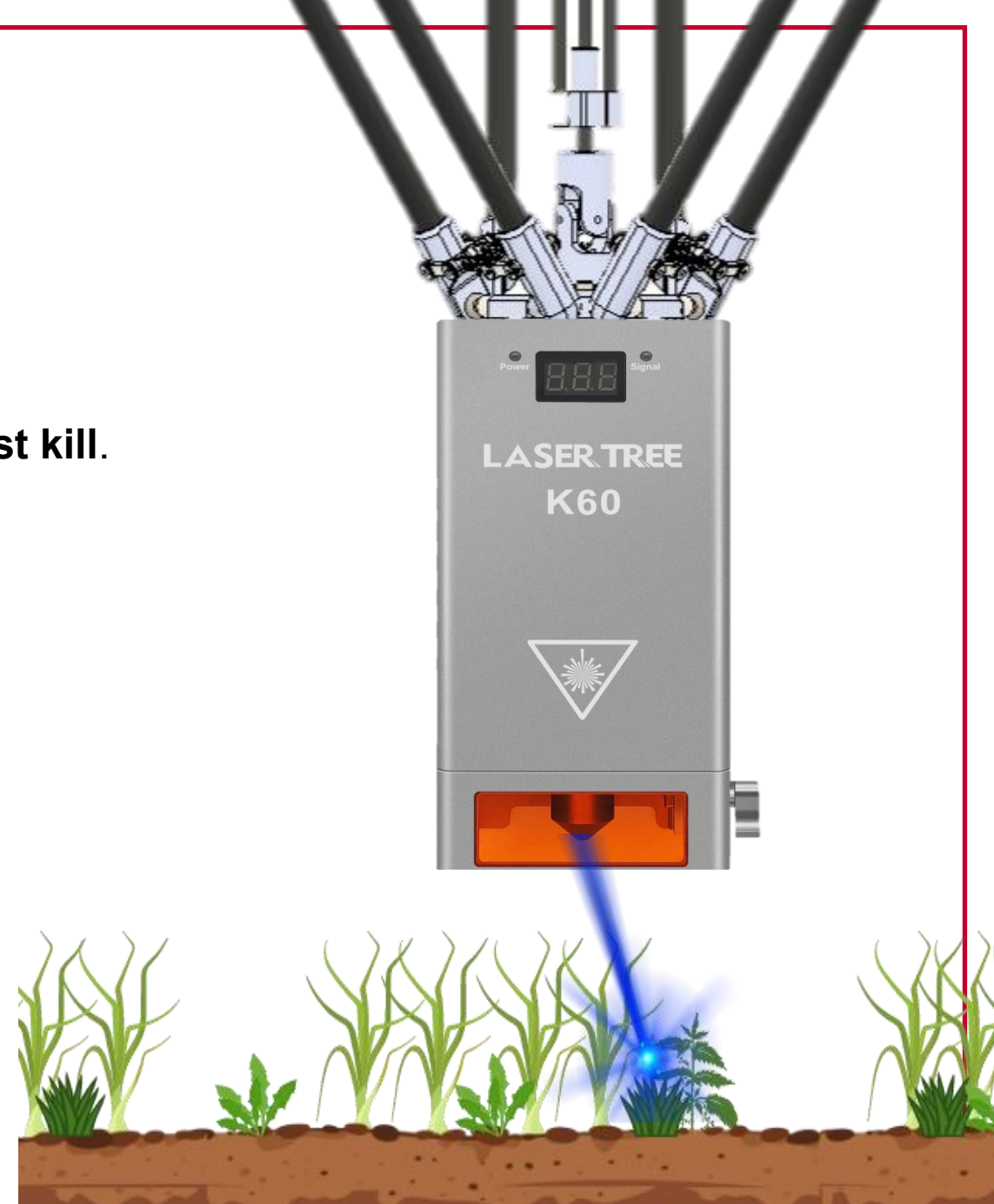

3. **Amiga**: The 4-Wheel Carrier Base Robot

Drives autonomously through the onion fields, row by row

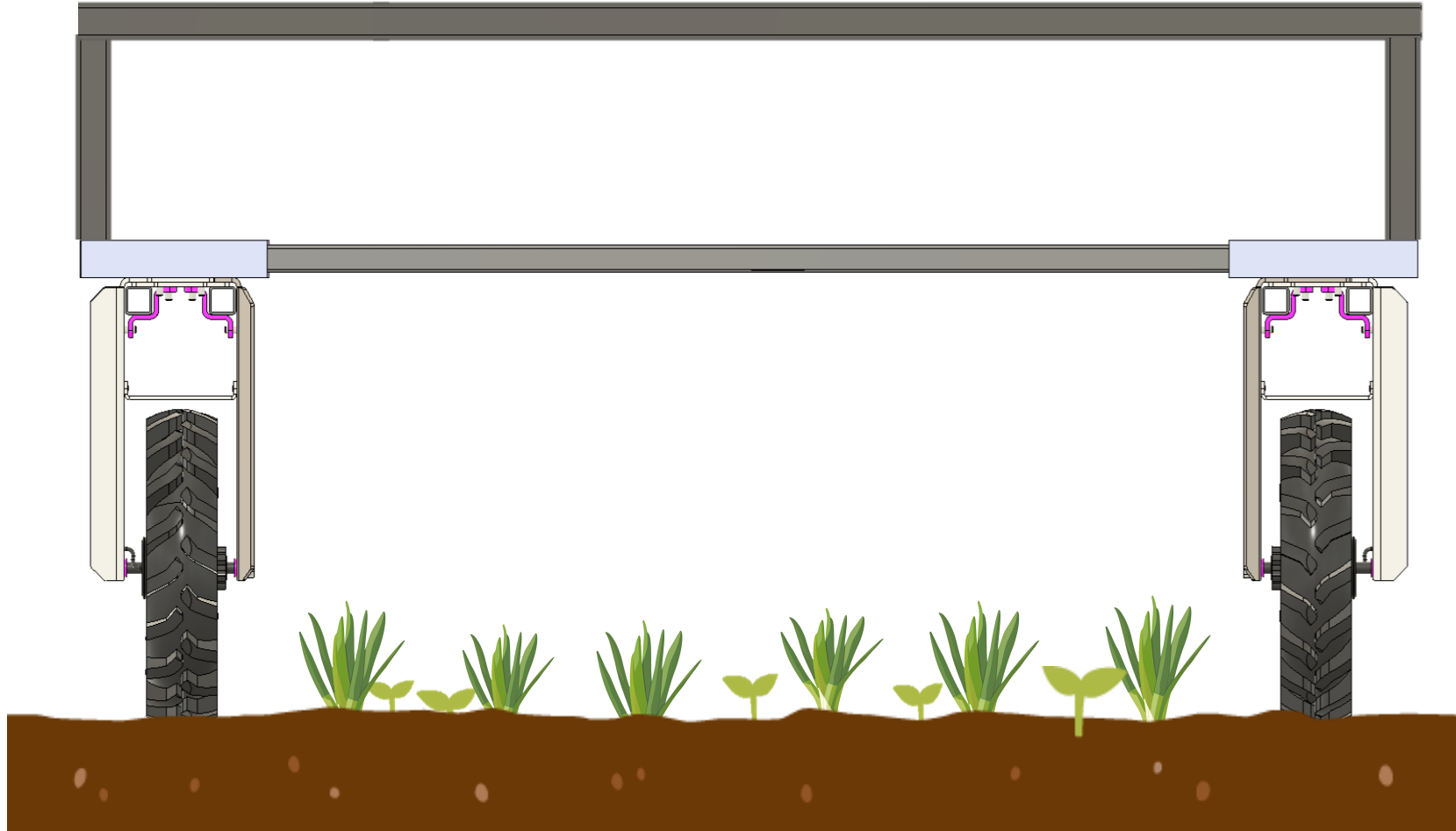



Precisely targeting weeds with Diode laser and delta robot

Experimental Setup





Precisely targeting weeds with Diode laser and delta robot

Experimental Setup

Experimental Setup



Experimental Design

Target Specie: *Brassica rapa* var. *Twister*



Standardized weed size (± 1.5 cm)



Uniform growing conditions



Response Variables

Chlorophyll Content Index (CCI)

Visual Necrosis Score (0–4)

Half-Rossette Span Change

Height Change

Temporal Monitoring Protocol

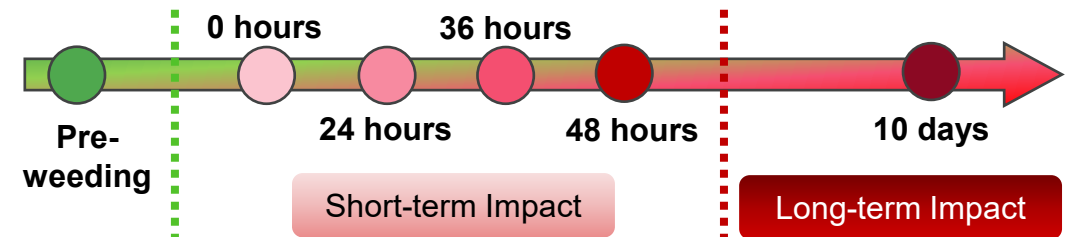

Results: Delta Robot Positional Accuracy

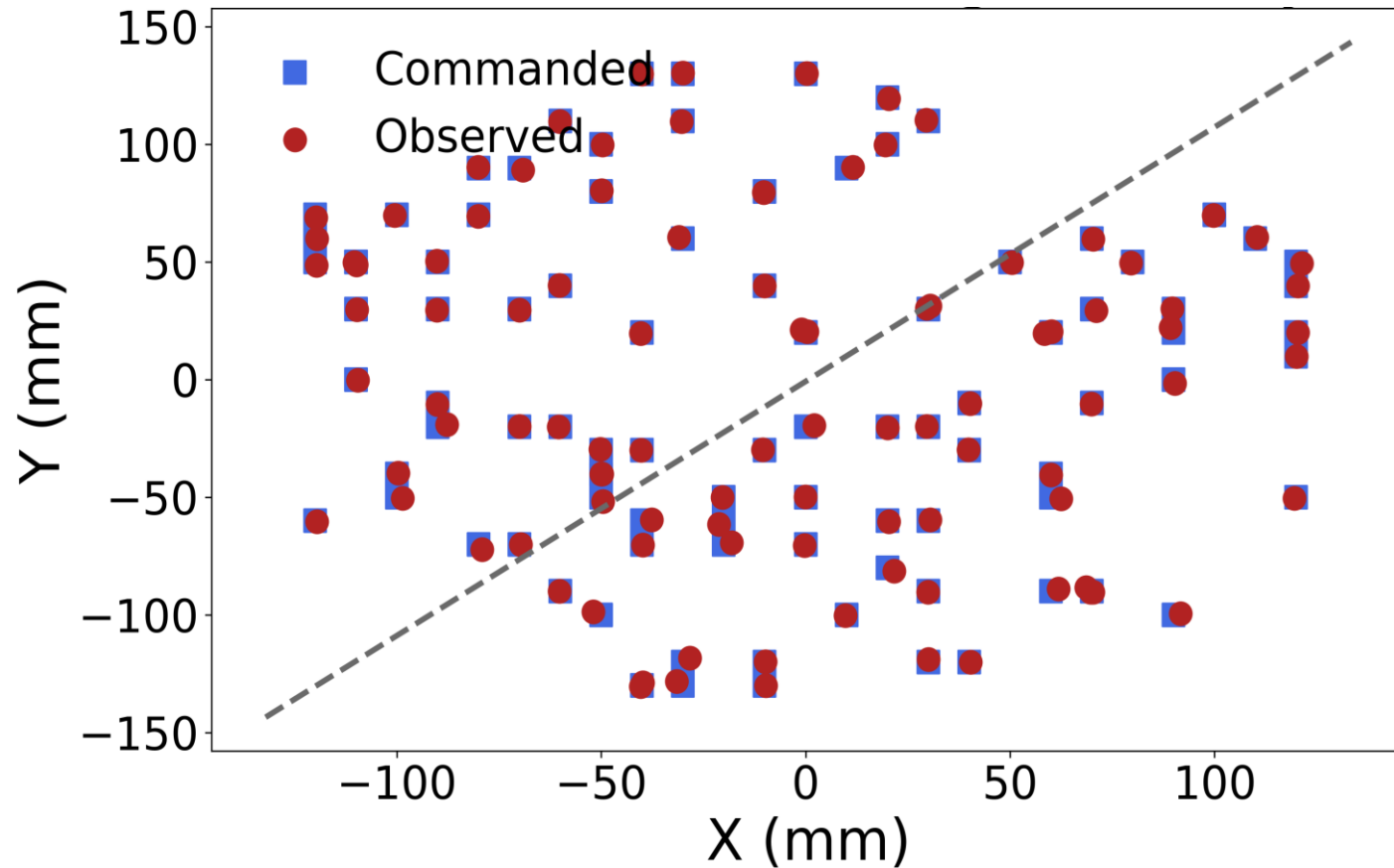

Commanded vs Observed Delta Robot Positions

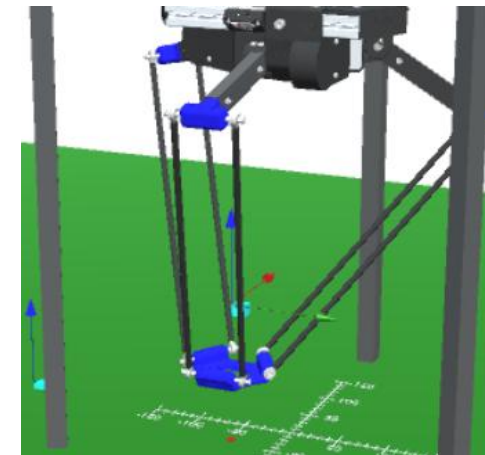
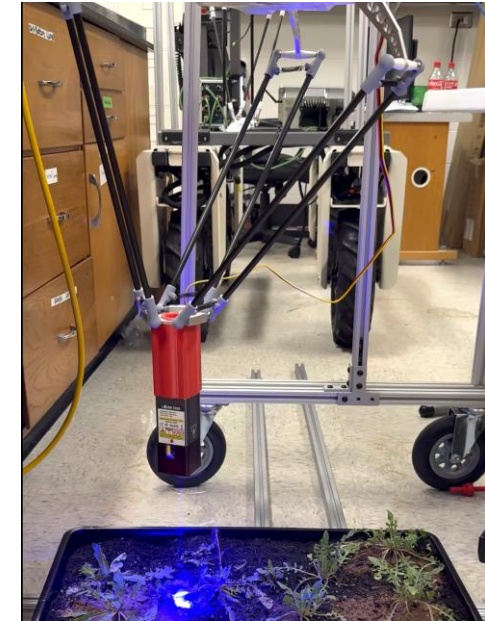

Results: **Field Validation**

Overdosing weeds by flashing laser for 3s, 2s and 1s



Results: **Visual Necrosis Score**



Before



After

Results: Visual Assessment

3 s Laser Exposure

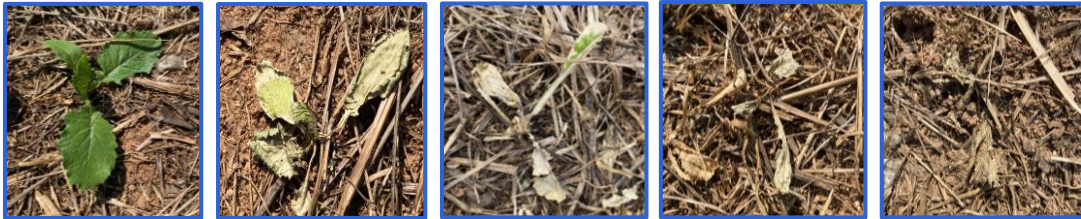

Baseline 24 hrs Post Treatment 36 hrs Post Treatment 48 hrs Post Treatment 10 days Post Treatment

2 s Laser Exposure



Baseline 24 hrs Post Treatment 36 hrs Post Treatment 48 hrs Post Treatment 10 days Post Treatment

1 s Laser Exposure



Baseline 24 hrs Post Treatment 36 hrs Post Treatment 48 hrs Post Treatment 10 days Post Treatment

0.5 s Laser Exposure



Baseline 24 hrs Post Treatment 36 hrs Post Treatment 48 hrs Post Treatment 10 days Post Treatment

Results: Laser Effectiveness on Weeds

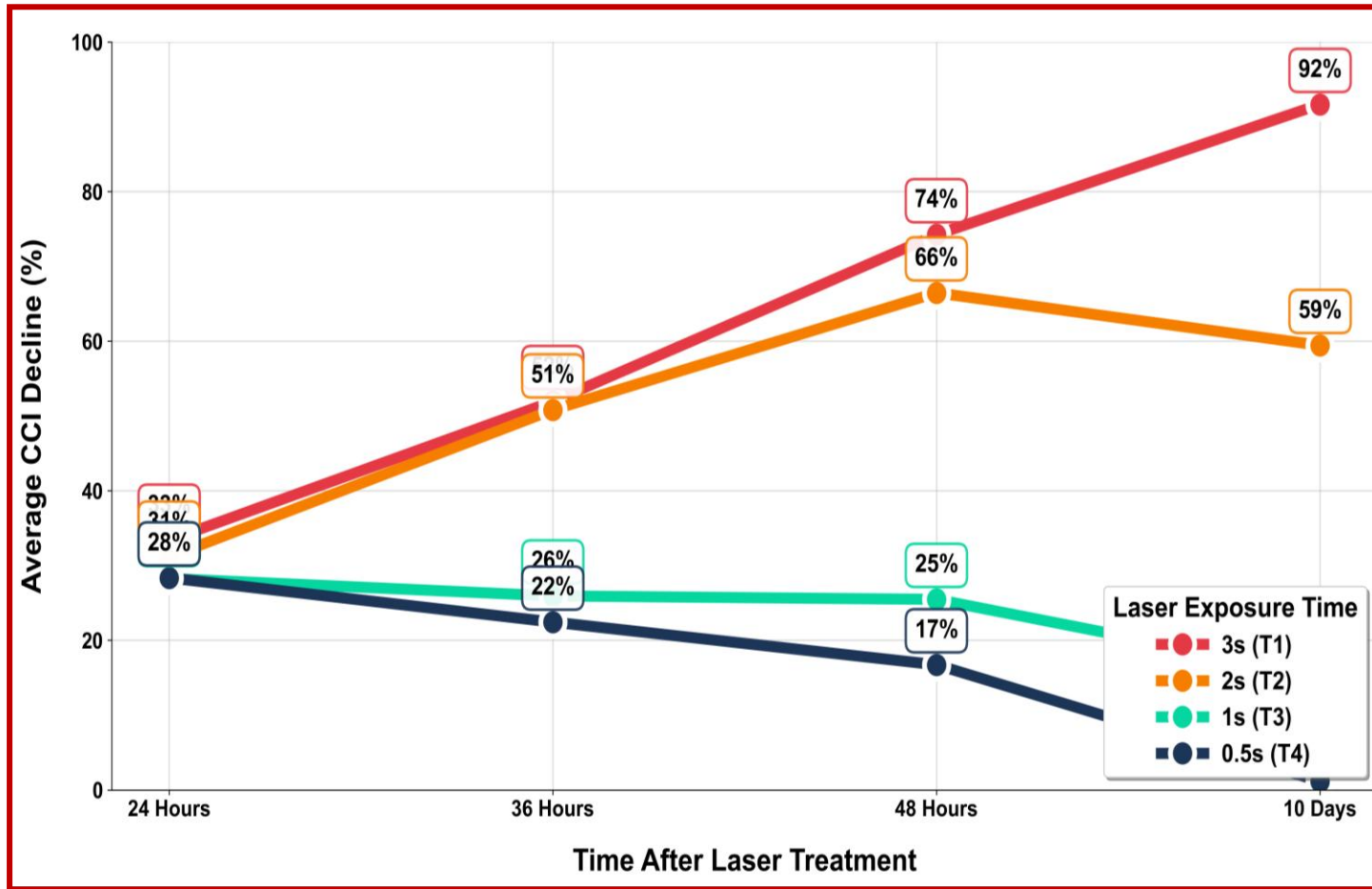

Average chlorophyll degradation over time

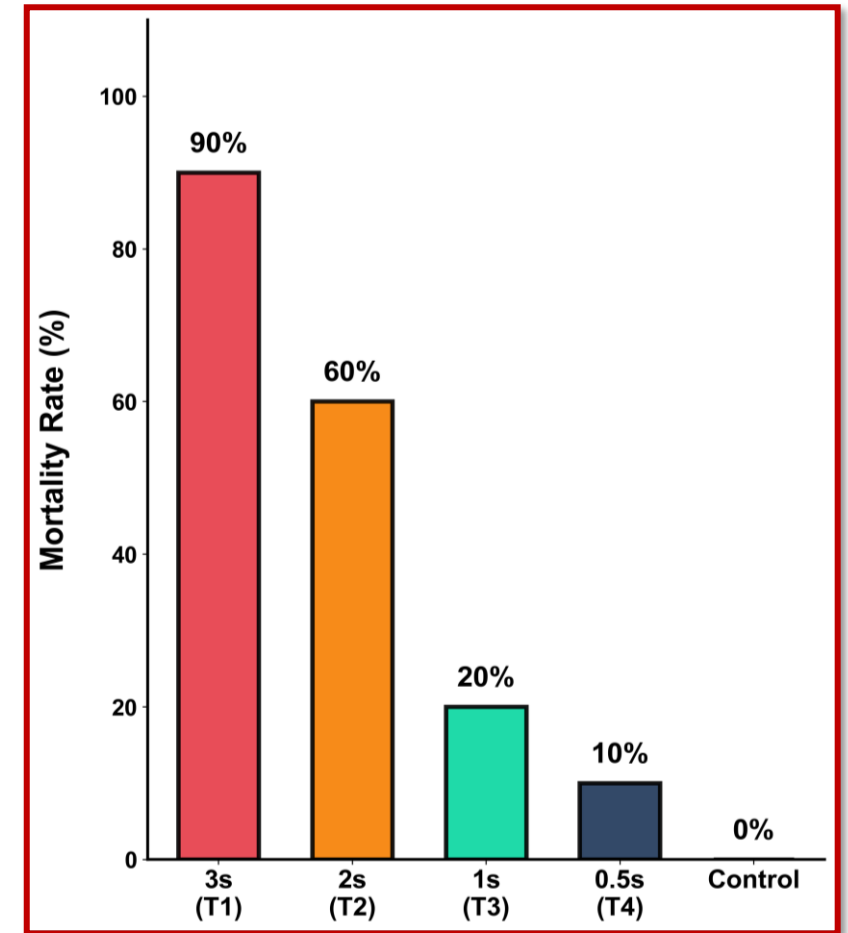

Weed Final Mortality Rate

Future Directions: A.I based Weeds Detection

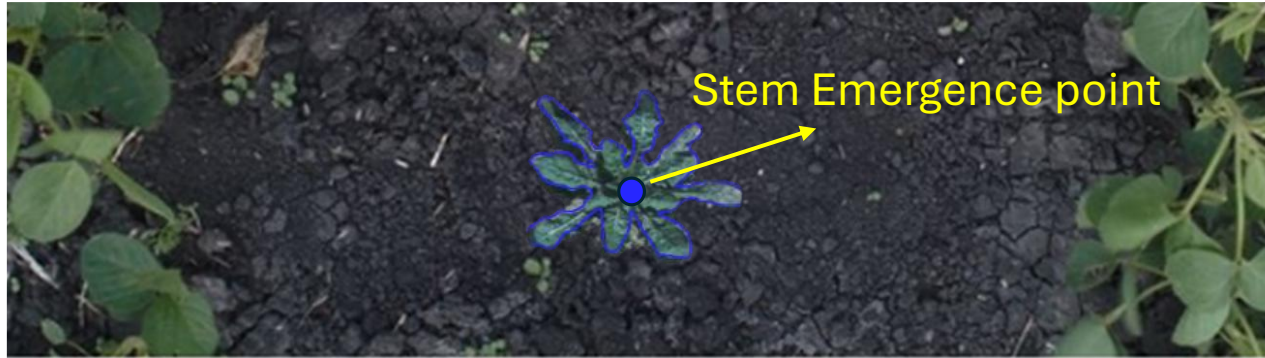

Future Directions: Autonomous Field Navigation

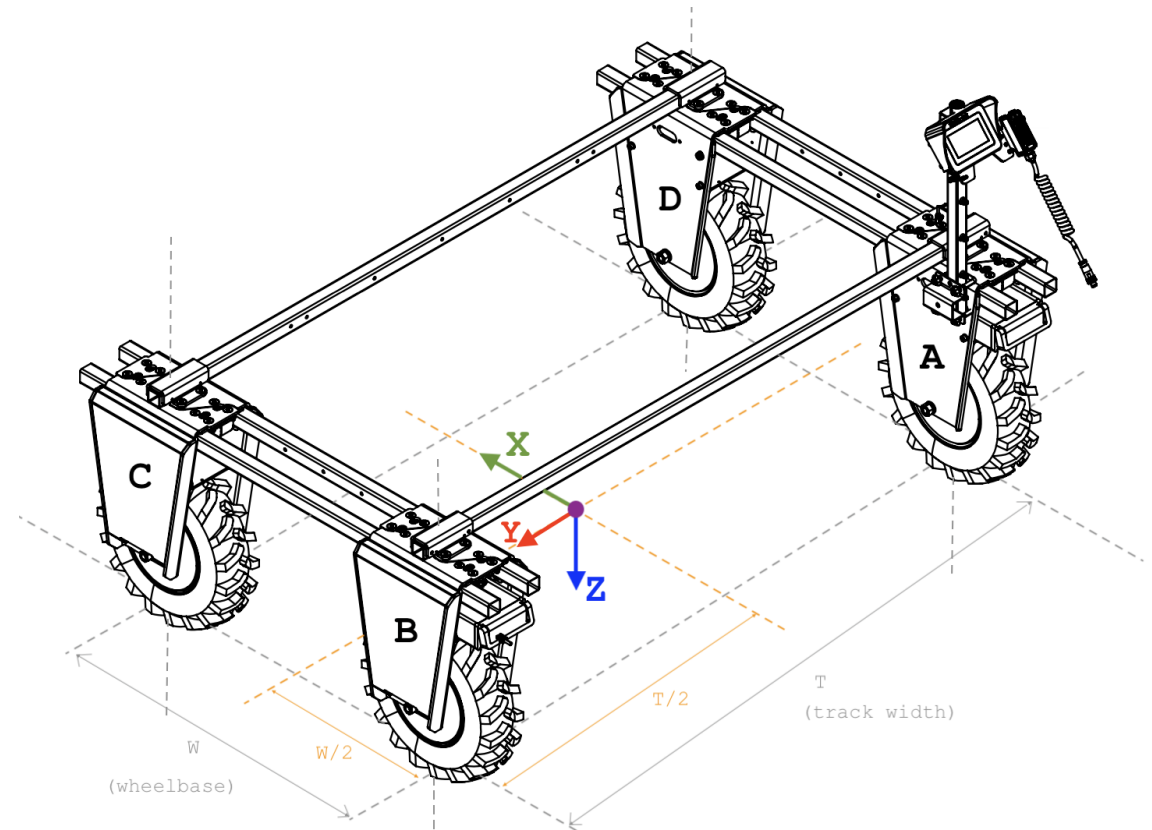

Conclusion



Achieved 90% weed mortality within 48 hours with a high-power diode blue light laser



Prevented crop damage by sub-millimeter delta-robot targeting



Future work would involve real-time stem emergence point detection

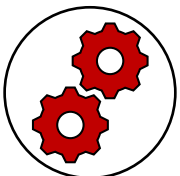

Integration with AI-based vision system would enable fully autonomous and organic weed control in Vidalia Onions

Acknowledgements



Institute for Integrative
Precision Agriculture
UNIVERSITY OF GEORGIA



GS24-316



Vidalia Onion Committee



Thank You

~~For further queries:~~

Contact | MuneebElahi.Malik@uga.edu

Principal Investigator | s.mahmud@uga.edu



UNIVERSITY OF
GEORGIA