

Farmer Built Pearling Machine Construction Manual

SARE Grant FNE19-945



By:
Nigel Tudor
Weatherbury Farm
1061 Sugar Run Road
Avella, PA 15312
Info@weatherburyfarm.com
724-587-3763

This material is based upon work supported by the National Institute of Food and Agriculture, U.S. Department of Agriculture, through the Northeast Sustainable Agriculture Research and Education program under subaward number FNE19-945.

Any opinions, findings, conclusions, or recommendations expressed in this publication are those of the author(s) and do not necessarily reflect the view of the U.S. Department of Agriculture.



The inception of the idea for this project came from a 2009 stop at an organic grocery store in Linz, Austria. It had products from Kettler Biohof, an organic grain farm in northeast Austria. In addition to many grains, rolled products and flours the store had pearled spelt, emmer and einkorn that they were calling rice (Dinkelreis, Emmerreis & Einkornreis).

The serendipitous visit to the organic grocery had a significant impact on our farm. We purchased a small bag of einkorn which we planted and started bulking the seed in 2010. After a few setbacks, we are on track to plant a small field of this einkorn in 2023. Similarly 12 seeds of emmer that we got at Agritechnica 2011 is now grown on the farm in field size.

When we started our flour mill in 2014, I kept thinking about those pearled grains in Austria. I knew that Farro from Italy is lightly pearled emmer (and we were bulking up our own emmer) and that barley is perhaps the most recognized pearled grain in America.

After doing some investigation I found that industrial pearling machines are mammoth and use 100-250hp. I did find some smaller machines in Europe but they used 20hp or more. This was too much to run on our farm's electrical service and would be the same for many farms in North America. Over time, I began to think what if the machine was scaled down to run on 10hp?

I designed this machine looking only at pictures, specs on websites and a couple short YouTube videos. Unlike my previous spelt dehuller SARE Grant where I was able to look at many different spelt dehullers in person, I only know of one pearling machine in the Northeast which is a vertical design at Maine Grains and not really applicable. My design was influenced by one Italian machine and 2 Chinese machines. I also looked at rice polishing machines which are a close cousin to pearling machines.

Also in researching pearling machines, I saw a couple of reports that pearling could reduce vomitoxin in small grains. On the last page of this manual I have the results of the vomitoxin reduction tests I carried out.

This project took a good bit of time and money. The drafting took over 95 hours, the fabrication took 315 hours and the project cost over just over \$7,300 to build. Make sure you have adequate time and money to finish this machine before you begin.

Please feel free to contact me and I can let you know how I am currently using the machine and any design changes I would recommend.

Happy Pearling,

Nigel Tudor

Weatherbury Farm

To make this project you will need:

A stock cut off saw to cut material to length.

A MIG welder capable of welding 3/8" steel. A stick welder could be used but I think a MIG is a good addition to any farm. I also used a TIG welder for some of the sheet metal work but you can use a MIG welder and grinder with good results.

A lathe and mill and the subsequent training on their safe operation opens up a realm of possibilities for any farm when it comes the repair, customization and construction of farm machinery. For this project I used a Clausing 1400 lathe (14" x 30" work envelope) and a Deckel FP2 milling machine. Any lathe with a comparable work envelope will work and the more ubiquitous Bridgeport milling machine or its legion of knee mill clones will also work. A rotary table would be nice for some parts but you can also get a local shop to do that work for you if needed.

For some of the parts I used my bandsaw to cut out internal openings by cutting the blade passing it through a hole in the work piece and rewelding the blade. I would then cut out the hole and cut the blade to remove it. If you don't have access to a metal bandsaw just have your steel supplier plasma cut those parts.

For the sheet metal work a shear and leaf brake were used. If you don't have sheet metal equipment you can get a local shop to do the work for you. In a pinch you can cut the sheet metal with a cutoff wheel in an angle grinder and weld the corners and grind them flush.

I used a mix of water jet and plasma cut parts. If there needed to be a surface milled , a hole drilled or tapped near a cut edge or if I needed better precision I used water jet cutting. For everything else I used plasma cutting. All of the water jet and plasma work was done by my steel suppliers.

To carve the stone I used a 4 1/2" diamond wheel in an angle grinder and a Trow and Holden 3/4B air chisel.



Here are pictures of the finished pearling machine from different angles.

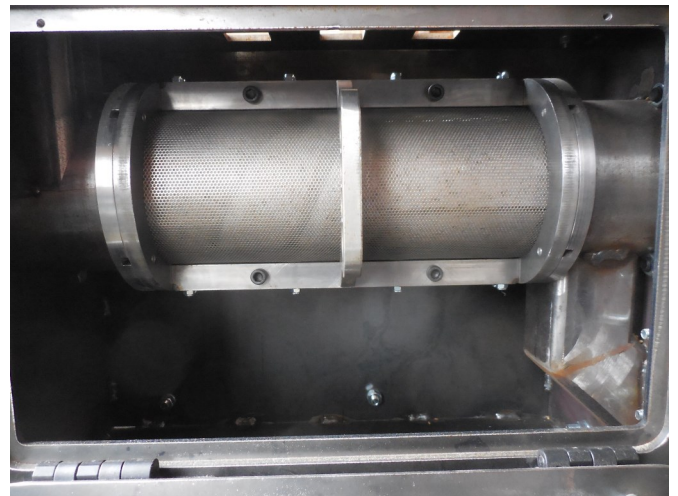

Fabrication of Base:



Measure diagonally to check square. Get the two diagonals to match within an 1/8" or better. Recheck after tack welding. Also, grind off the mill scale at all of the weld locations before assembly.

Sometimes you can use a wood working clamp to hold things while you tack weld. Make sure you position the end piece that holds the discharge chute correctly.

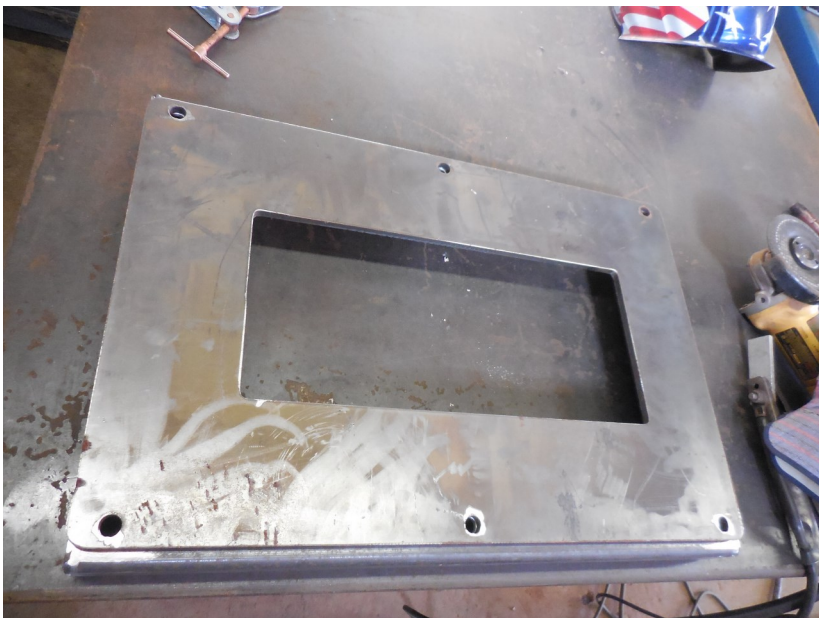

After tack welding, check that the mating pieces align to the mounting holes correctly before finish welding.

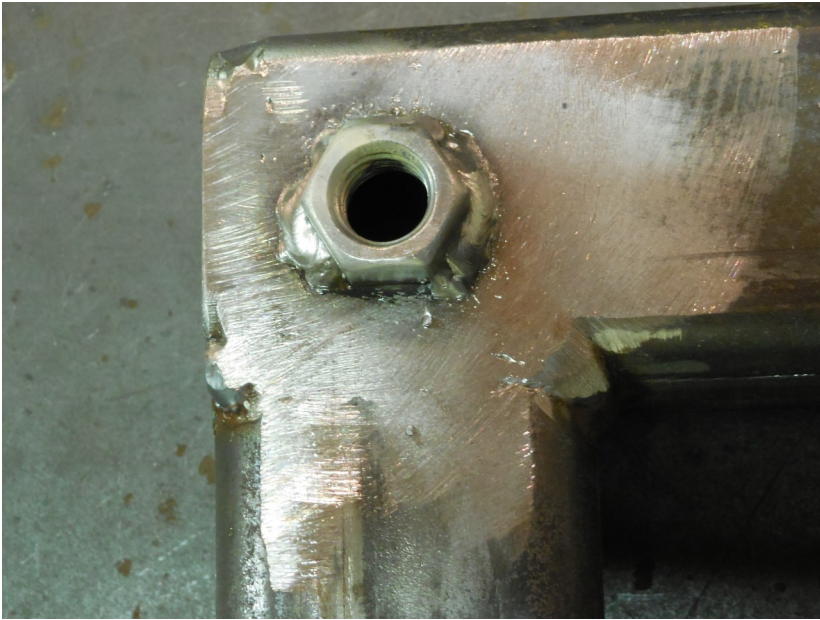

5 of the 6 mounting holes are over legs and have nuts welded on the back side. First I sanded the zinc plating off of the sides of the nuts. I welded the nuts on 5 sides leaving an unwelded side on the side closest to the tube. I didn't want the weld to interfere with the tube.

I used some precisely cut pieces of lumber to space the legs correctly. I used the square to keep the top square to the legs. Only tack weld it at this step.

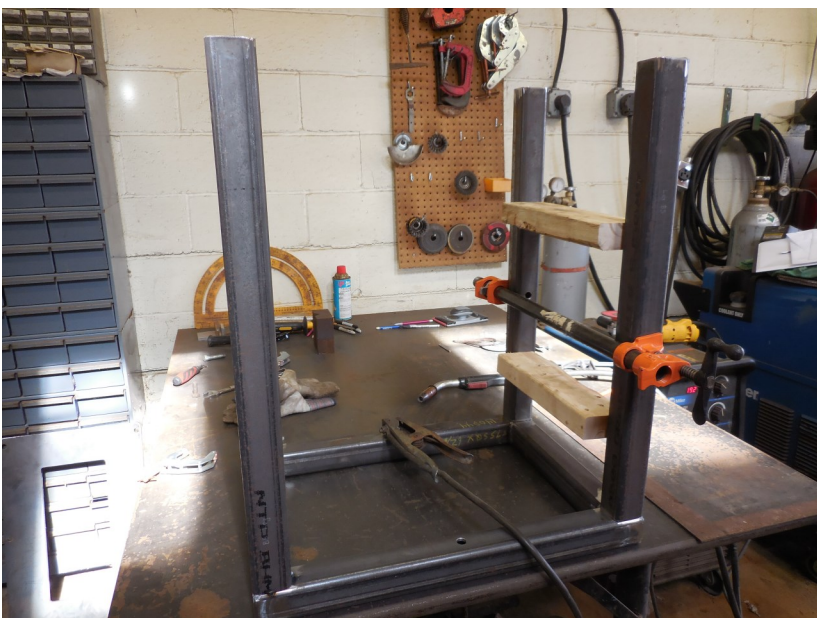
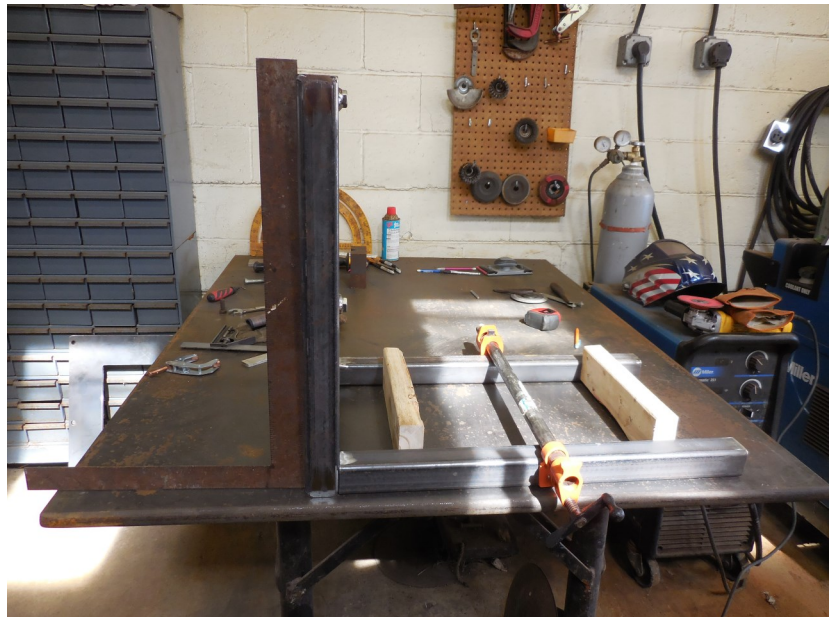

I used the same lumber trick on the other legs.



I used 1/8" pieces of stock to space the 1/2" threaded rods on the 1/4" plate correctly. Tack the shafts and then check that threaded rods are parallel to each other and square to the plate before finish welding.

Make sure the ears for the threaded rods on the motor plate are spaced correctly before finish welding. I left a section in the center unwelded as the weld in that area could interfere with the adjuster nuts.



Fabrication of bearing holder:

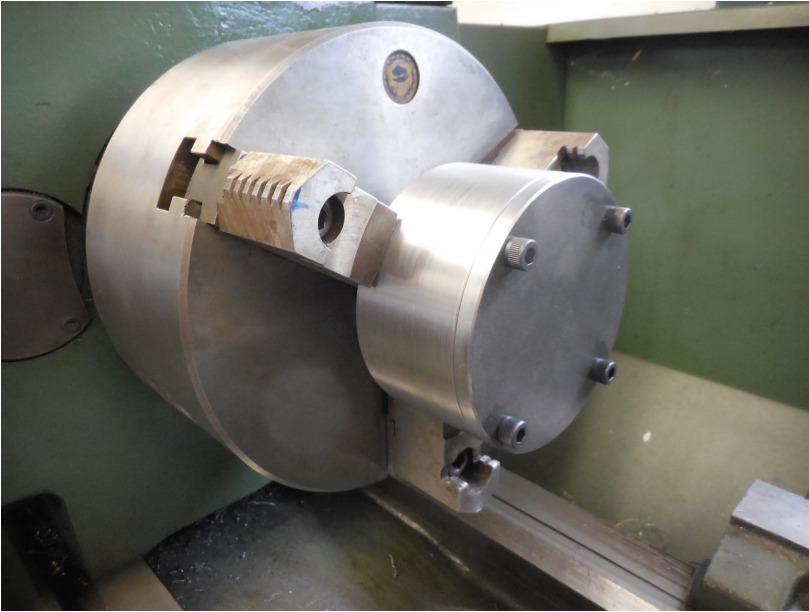

To true up front cover attach it to the holder and make a skim cut.

Take a skim cut to remove mill scale in the weld area. Align the holes between the two pieces before pressing together.



After welding take a skim cut to flatten the back of the bearing holder.

Door Hinge Construction:

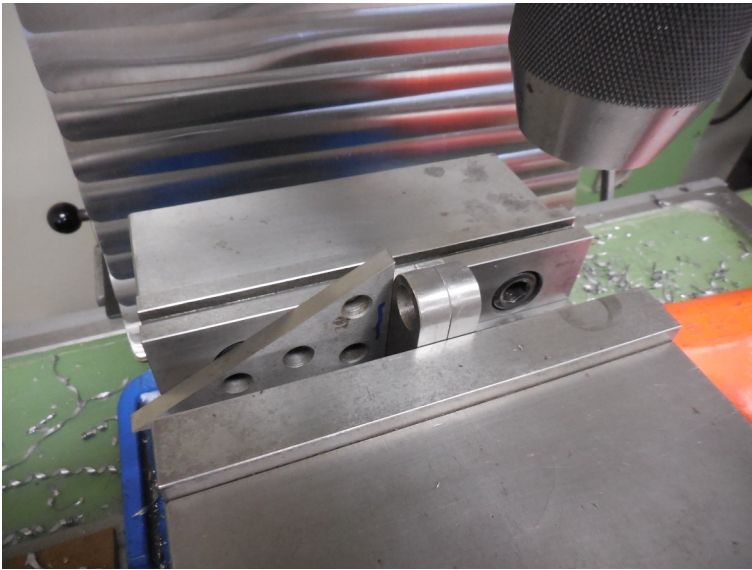

I put 6-32 set screws in the top of the door hinges. I used a square to align the hinges vertically in the vise .



Scribe lines to align the broach to cut the keyway in the same orientation on both door side hinges.

Fabrication of housing end plates:



To hold the plates, I reversed the jaws to the outside of the vise and used machinist jacks to support the ends.



I put 2 $\frac{1}{8}$ " diameter reamed holes to aid in the location of mating parts. I positioned the reamed holes 2.75" of the centerline of the main shaft.

Fabricating screen holder:

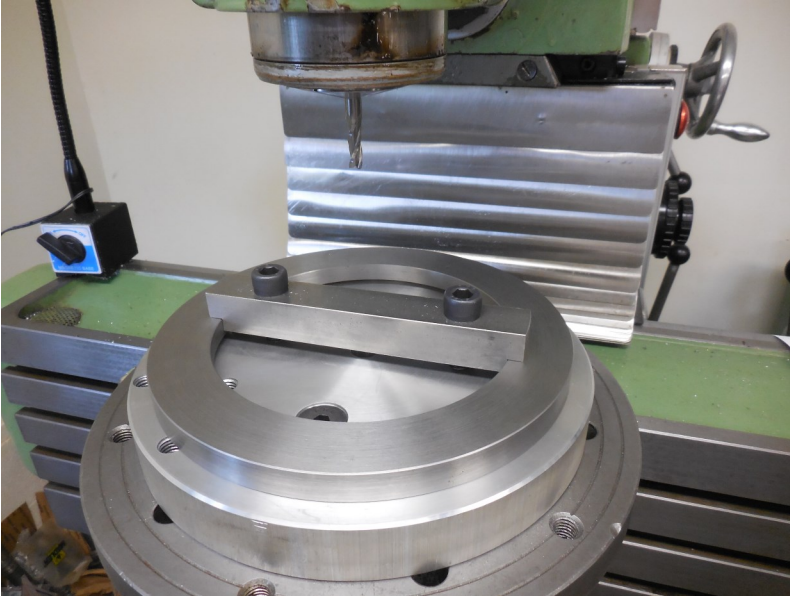

To make the screen holders I made an aluminum mini pallet to go on the faceplate of my indexing head. I made a clamp that has pockets milled on the end to match the internal diameter of the parts.



I used a center cutting endmill to cut the hole that holds the screen holder pin. This is a good tool to use when there are features that would affect a drill.



A good light helps you see what you are doing.



I used the mini pallet with the alignment dowel pins to transfer the alignment pin locations to the other end of the tubing.



I used center cutting endmills to machine the radii in the corners of the tube. I stepped up the hole size in a couple of steps as my setup did not have the rigidity to do it in one operation. Then I used a smaller endmill to remove the material.

I used a horizontal spindle to machine this but you can use a vertical rotary table to do this same work on a vertical mill.





I had to take some light skim cuts to bring the tubes to nominal size so they fit in the holes previously milled.



Originally I was going to mill the radius for the tube ends but my mini pallet wasn't big enough to adequately hold the tube.

I inserted the square tube into the round tube and marked the radius with a scribe. I then used my belt sander to grind this radius. Several test fits and selective grinding got the radius correct.

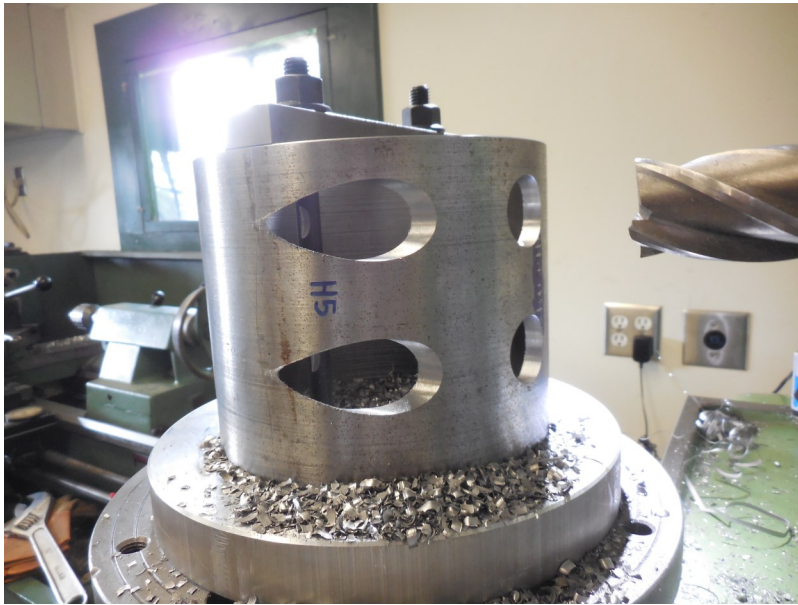

The outer holes were a little difficult as they were deep holes with uneven side loads. I just took it slow .



I used a 1/2" endmill to remove the metal between holes on the top, bottom and rear. I used a hacksaw between the two front holes to remove the center drop. I then cleaned up the floor with the 1/2" endmill.

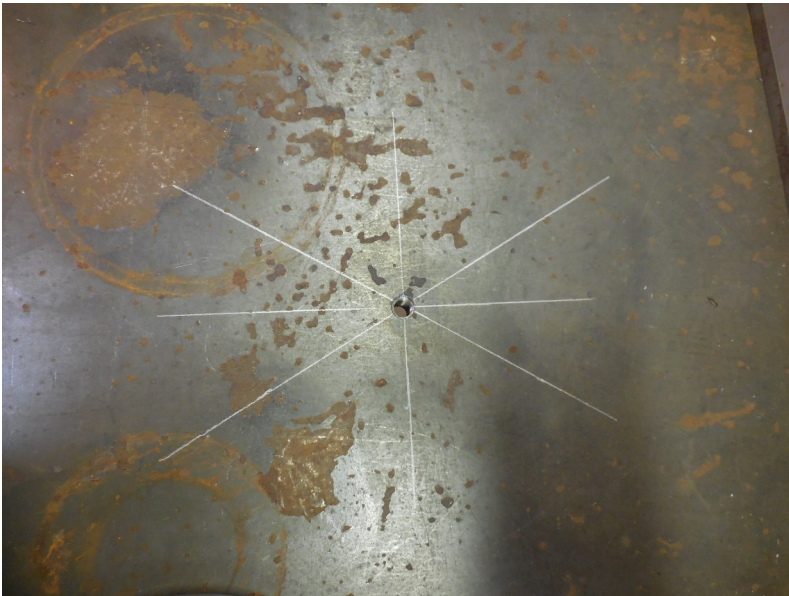

I drilled and tapped a hole in my welding table to use the hold down clamps used on my milling machine. I also laid out lines at 90 and 120 degrees.

I laid out 1" welds 120° apart. I used minimal welds to minimize distortion. The clamp was firmly tightened down to prevent any shifting during welding. The 1/8" dowel pins kept everything properly aligned.

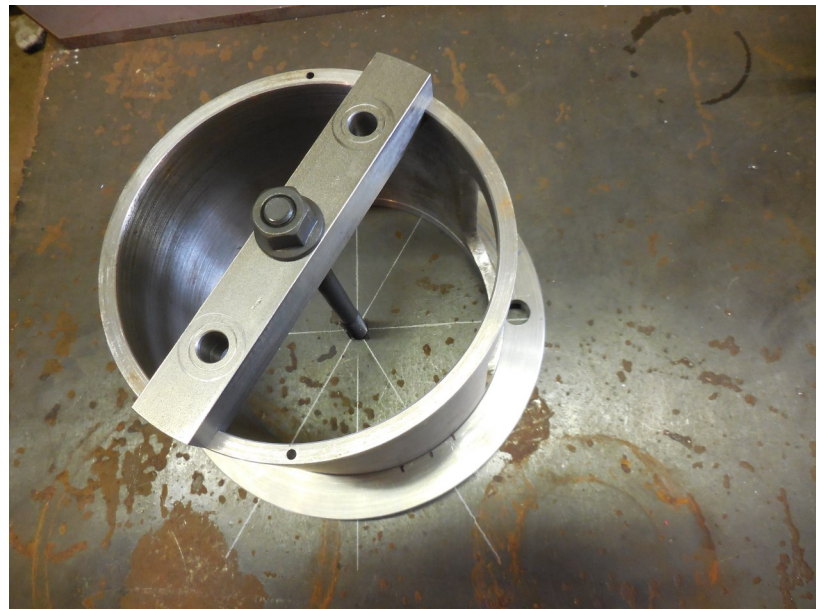

The screen holder pin was turned to be a press fit into the screen holder ring. The part that engages the screen was 0.500". Install the screen holder pin before welding the assembly to the outer plate. Once again I used three 1" welds 120° apart.



Use a piece of sheet metal to cover the screen holder ring so it doesn't get weld splatter on it.

Use a bolt to hold assembly firmly to prevent shifting during welding. Also remove mill scale in weld areas.

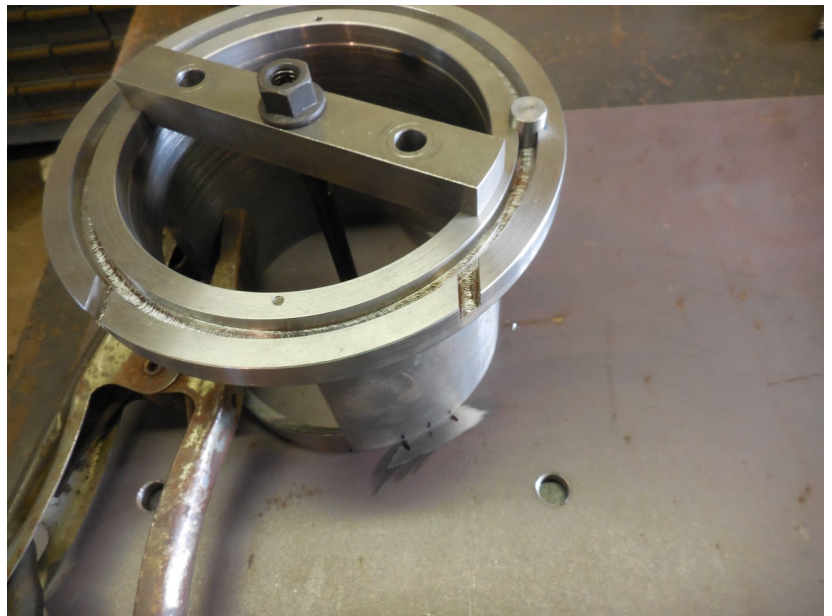

Dust collector hookup fabrication:



One trick to do internal cutouts is to drill holes in the corners. Cut a bandsaw blade, pass it through the hole and reweld the blade. Keep in mind cutting in one direction or the other might work better with the throat clearance.

You should have at least 2 teeth in cut. I used a 32 tpi blade for 16ga steel.

I combined the two 4" diameter parts on the dust collector. I used a offcut to put the fine point sharpie at the correct height to mark the cutting line.



I used a thin cutting blade in the angle grinder to make the cuts. Deburr cuts after cutting. Also remove the aluminized plating before welding.

You can use a Mig welder or Tig welder to assemble the sheet metal parts. I used a Mig welder on the dust collector and a Tig welder on the hopper. A nylon backed disc sander makes cleaning up welds easy.

Feed gate fabrication:

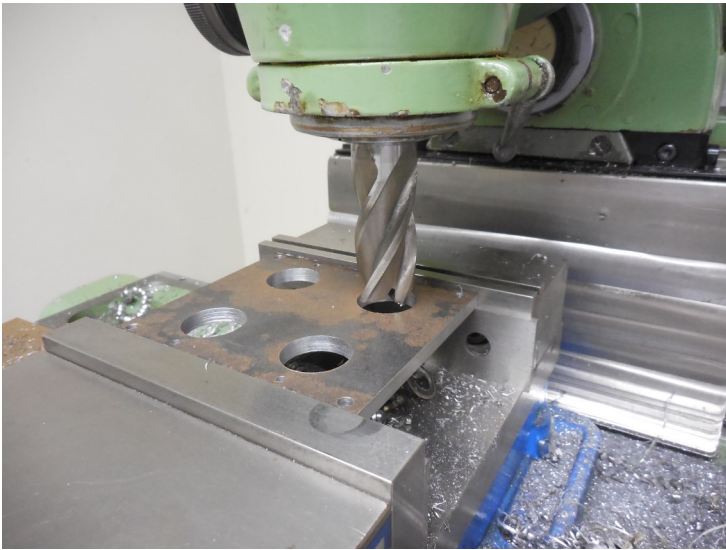

I used a center cutting endmill to make the radii in the corners of the internal square holes in the feed gate plates. I cut the saw blade, passed it through the holes and cut out the center.

You could also use an annular cutter instead of a center cutting endmill.

Cutting the center out of the feed gate.



The rails are attached to the feed gate with 1/8" pin rivets. The holes are chamfered on either side to make a space for the heads. The rivets are cut 1/8" longer than the thickness of the gate and rails. I spaced it up on some scrap pieces of 16ga steel (1/16" thick). I used a ball pien to set the rivets on one side and flipped it over on the steel table and set the rivets on the other side.



After the pin rivets are set then they are filed flush.

The guide plates are also pin riveted on.

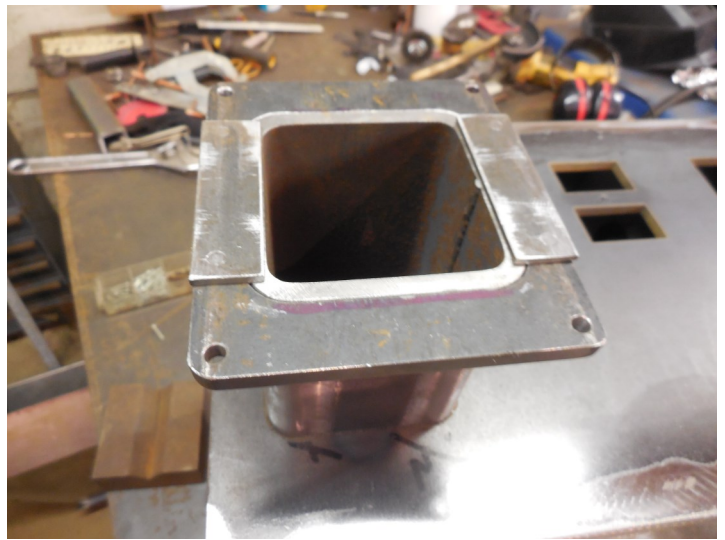

I used a large block of steel to hold the lower feed gate place in position and keep the tack welds from shifting its position. I used 4 generous spot welds to hold this in position. I didn't want to cause any warpage. And since the hopper is held on with 4 10-32 bolts, it is sufficient.



To put the feed gate screw together, I lightly knurled the internal parts and used the lathe tailstock to press them together.

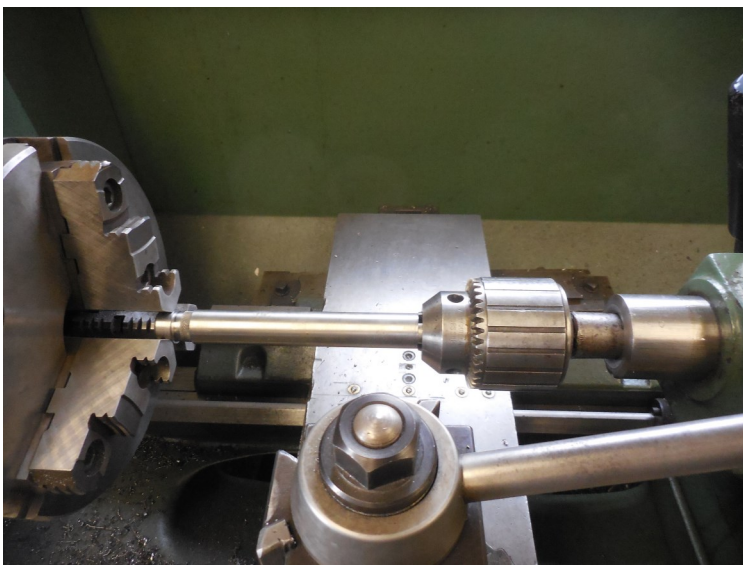

The feed gate scale didn't come out exactly as wanted. This is due to the fact my brake's minimum bend spacing was larger than the design. I will be reworking this design later.



Hopper fabrication:



I added a 3/4" wide flange around the top of hopper. I had trouble adding this flange to the digital model.

After welding, check the flange height side to side. Lightly sand the bottom to correct variations.

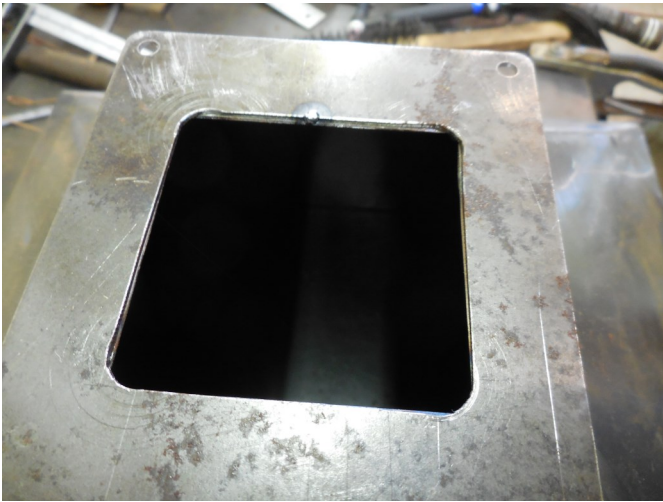

To attach the base. I made one tack weld. Then I drew a line on the table and visually lined up the lip with the edge of the table. Because there is just one spot weld you can shift the base to improve alignment. With a TIG welder, I just fused the base to the hopper and only used filler in the corners.



Screen Holder Fabrication:

To get the .938" thickness, I removed .031" from each side. You need to remove equal amounts of material from both sides or the stress from the cold drawing process will cause the pieces to bow. I milled each side half way while holding it in the vise and then moved the other half into the vise and machined it.



I didn't have a caliper or micrometer long enough to accurately measure the 12.5" length of these bars. I lightly milled each end to create a true surface. Then, I used a .5" diameter edge finder and read the difference between the two ends and made a mark with a sharpie how much still needed to be removed. Then with the edge finder in the collet holder, I re-picked up the end. I then swapped the edge finder for a 1/2" end mill and milled the bar to the correct length.

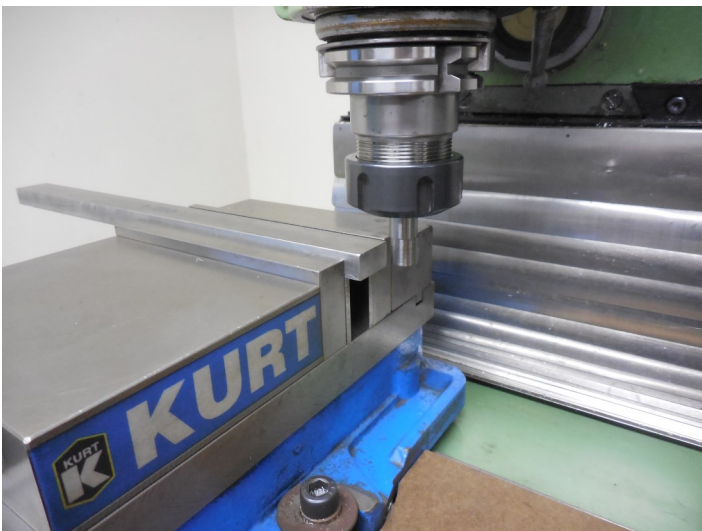

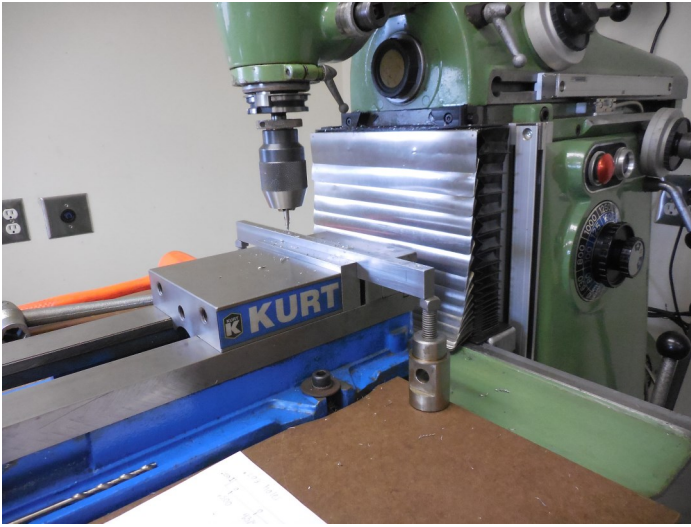

When drilling the .203" holes through the bar, I used machinist jacks on each end to keep the bar from shifting from drilling forces.

I drilled an undersized hole through to the .203 hole from the end. I then reamed the .125" hole .25-.3 deep. I used a sharpie mark on the reamer as a guide. You should put a drop of oil on the reamer or it might cut oversized. The reamer should be run at 25sfpm.

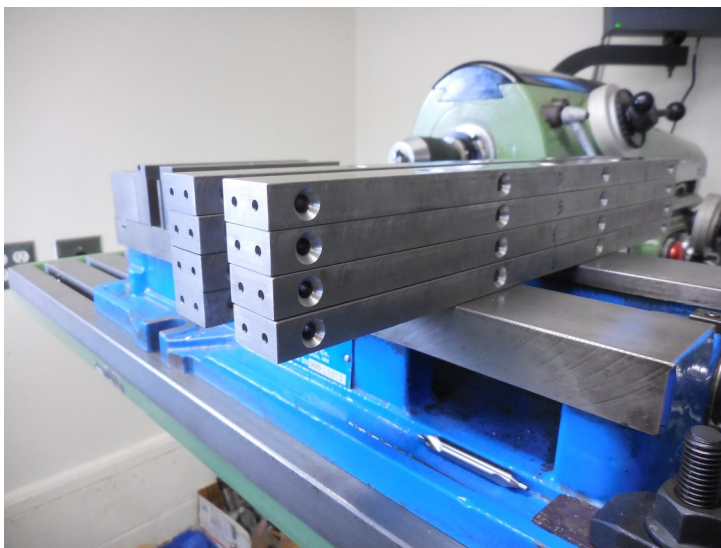
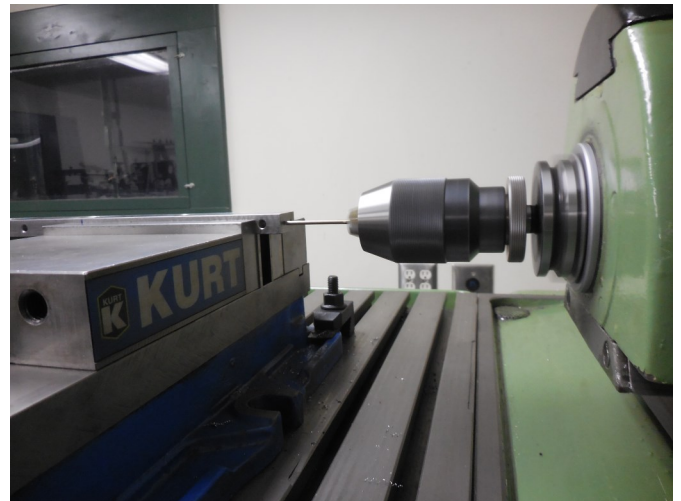

I also chamfered the holes to accept the flat head cap screws that will hold the screen. The counter-sinks allow the head to be below the thickness of the screen.

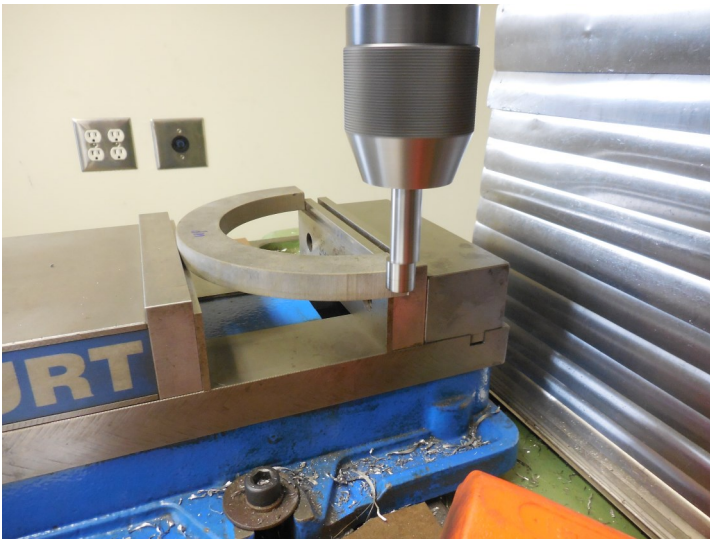

I used an edge finder .250" out from the vise and picked up each outside and then used the 1/2 function on my DRO to find the centerline. Lightly tap the pieces onto the parallels in the vise (make sure the parallels are firmly against the piece, by trying to slide them side to side).

I ended up drilling and reaming the .125 holes through so I had better chip evacuation and all of the features were done in one setup. I reamed the holes for the 1/4" dowel pins with a .2485" reamer. I kissed off the backside with a 3/4" endmill so there is a true surface for the bars to mate to.

I made my 1/4" dowel pins from 4140 PH (pre hardened) TGP (turned ground and polished) shafting. I made the pins .740" long so they did not impinge on the bottom of the screen groove.



You should make the screen holder ends before the end assemblies. The slots were a couple of thousands too tight. I had to pick up the center and widen the slots.



Chamfer the corners of the handles. Radius the points where the different radii come together. Make sure it feels good to your hand.

I clamped the frames together at the mating point. I also put the hand hold on the frame.

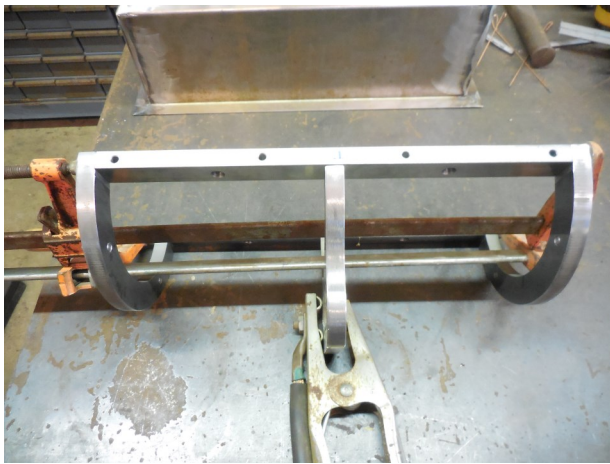
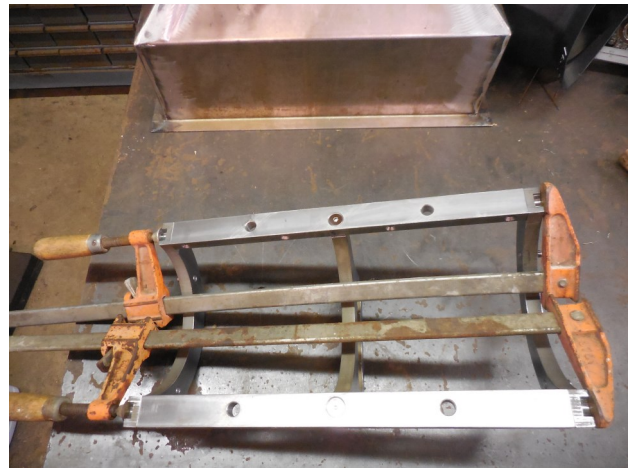

I used a TIG welder to fuse the outside of the end and bar and where the screen mates with the other screen. 2 side fused at the four corners.

I checked all of the screen holders at the bars; all of the screen holders were within .004" of each other. It fell off up to .011" at the center of the radius.



Pearling machine chamber housing fabrication:



Before drilling the hinge holes, I mocked up the door and surround to check that the spacing is correct.

I attached the door jamb with two 1" welds per side. I removed the mill scale in the weld area. I did not put the tapped holes in the door jamb before attaching it.

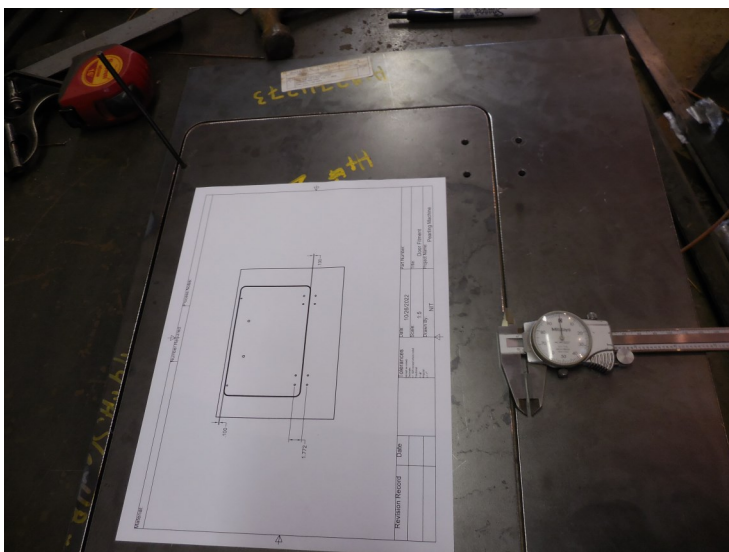

After welding on the door jamb, I put the door in the surround and set it with the correct gap around the door. I then transfer punched the location for the tapped hole on the door jamb. I did it this way because it would be too easy for the small tapped holes to be in the wrong location after welding the jamb in.



To minimize welding distortion I used a series of 1" welds to assemble the pearling machine housing. I removed the mill scale on all of the weld locations before assembling the housing.

Here is my cheat sheet for the spacing of the 1" welds.

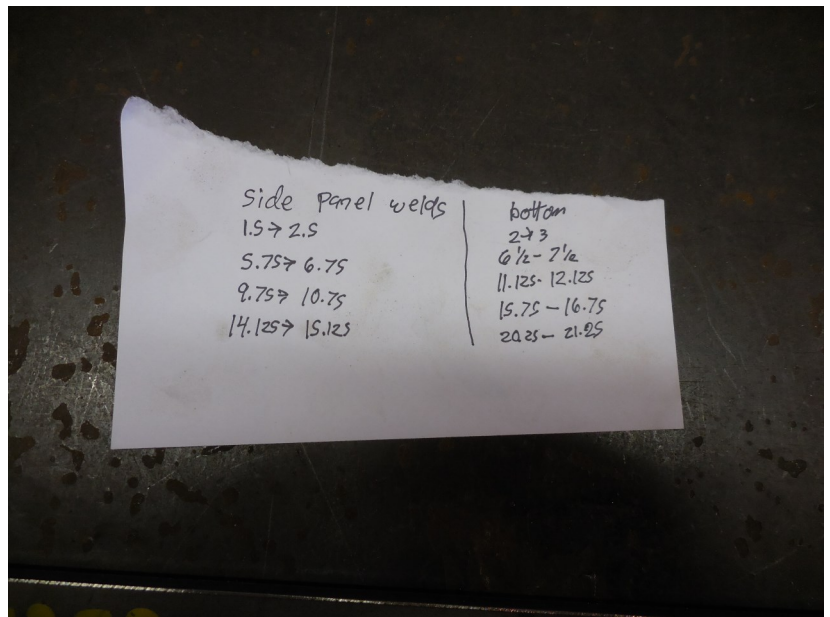

I used the screen holders to accurately space the end plates. I added a piece of feeler gauge at the infeed end on both side to add clearance. I used four clamps and four cap screws in the screen clamping holes.



Here is a close up of the feeler gauge in the assembly. I used .025" feeler gauge. This ended up not being enough to give adequate clearance. The feeler gauge is in the area where there was "droop" when I checked the frames with the height gauge. This effectively removed some of the thickness of the feeler gauge. After welding, the screens were a very tight fit. I lightly filed them on the areas they were contacting and now they slide easily. If I were to do it again I would use .030-.035" feeler gauge.

I covered the screen holders with aluminum foil to keep weld spatter off the screen holders.



I assembled the ends, door side and top first. I put tack welds on each end of the 1" welds. After putting the tack welds on all of the pieces I then welded the 1" welds. Then I welded the back on working through the door opening and the bottom opening.

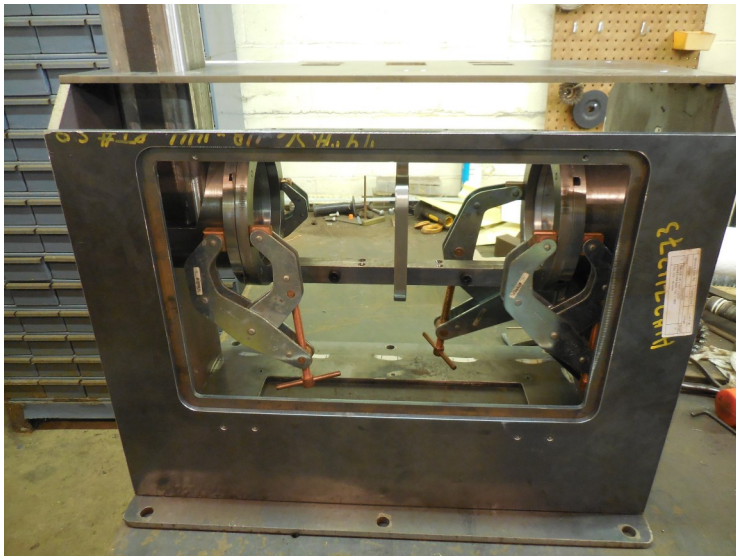

After welding the ends, top and door side.

The top panel had a slight downward curve. To fix this, I used a jack. I raised it up to be flat and then welded on the angled sides



For the angled pieces I started with .25 x 2.25 cold drawn 1018. I used a belt sander and chamfered the corners that touch the side and top. This left a minimal gap between the pieces which will help minimize welding distortion.

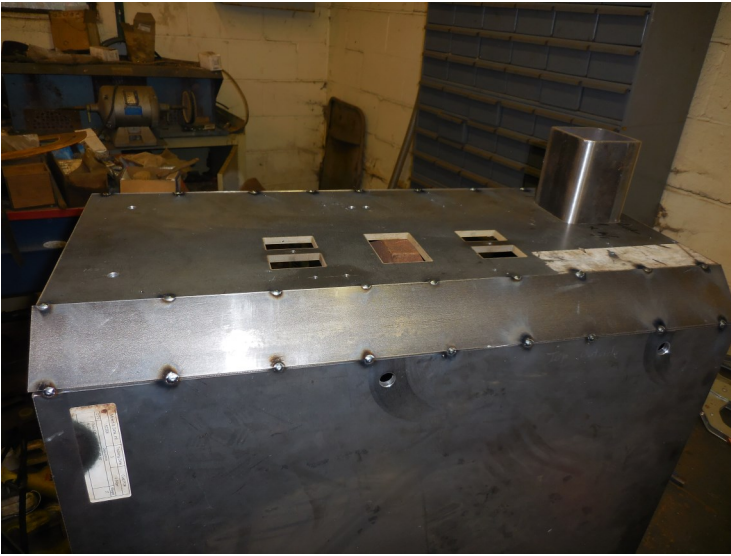

I made a series of 9 tack welds to hold the angle pieces in place. I then turned my welder down to the settings for 1/8" and filled in the crack in 1" sections. As I filled in the crack, I jumped around to minimize heat buildup and ultimately welding distortion. When I was done I ground the weld flush.

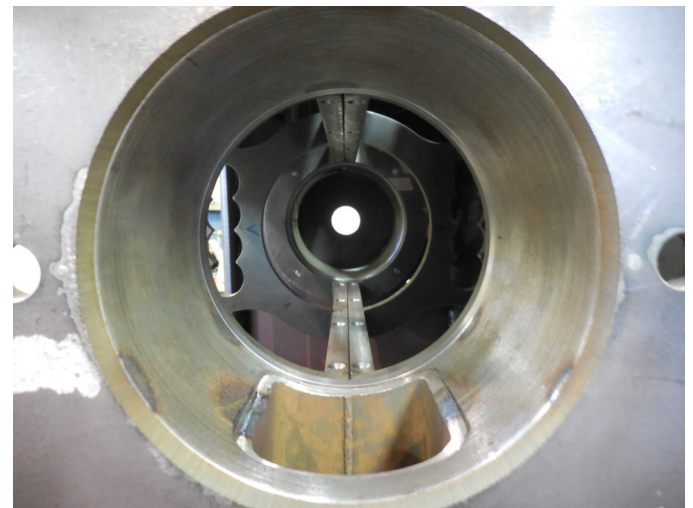

Looking down the bore of the pearling machine.

Control panel fabrication

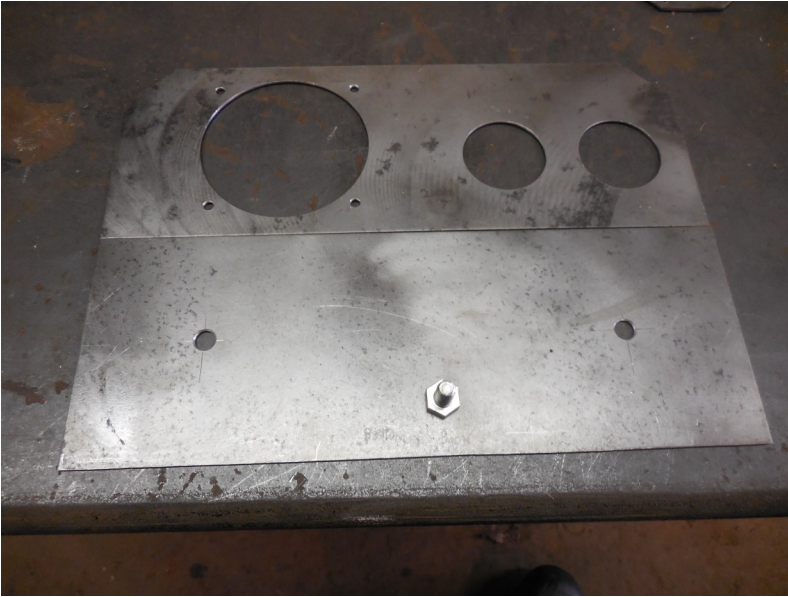

I welded a 1/4-20 short bolt on the bottom piece of the control panel. This will serve as a grounding lug.

The holes for the feed gate control didn't end up in exactly the right place. I put a piece of aluminum inside and plug welded the hole. I then ground the welds flush. I positioned the panel under the feed gate and transferred the centerline of the holes to the top of the panel.



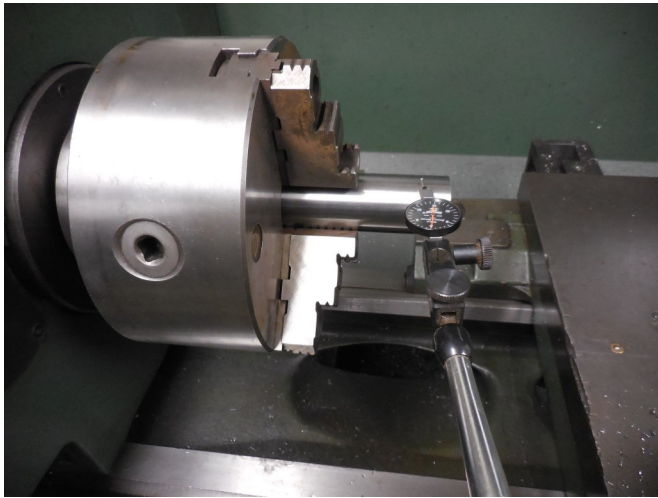

Check the shaft every time you chuck it for run out. Sometimes something can throw it off. With longer projections check it a two places.

My 3 jaw chuck was running under a .001" runout so I didn't use a 4 jaw chuck.

I used a center drill in a lathe holder as a form tool to put a 60° taper in the end of the tapped hole so I can use a center later to balance the shaft.

Make sure you can buy the 1/2-20 flat head cap screw that goes in this shaft. I ended up using a 1/2-13 cap screw as my hardware store didn't have 1/2-20.

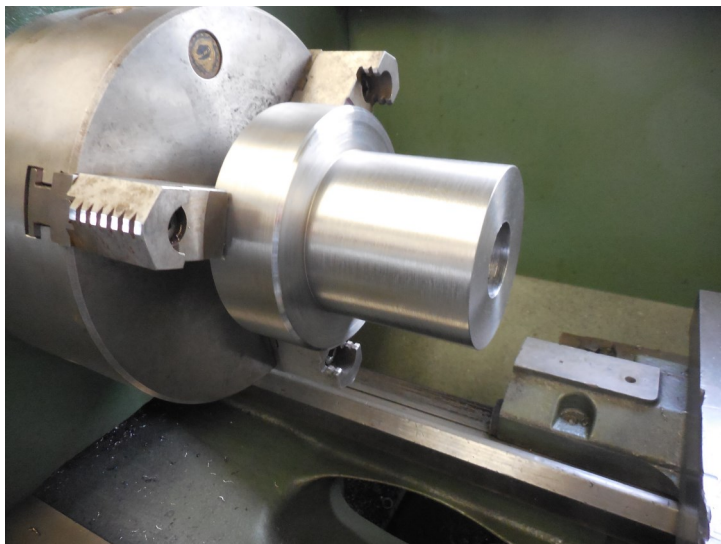
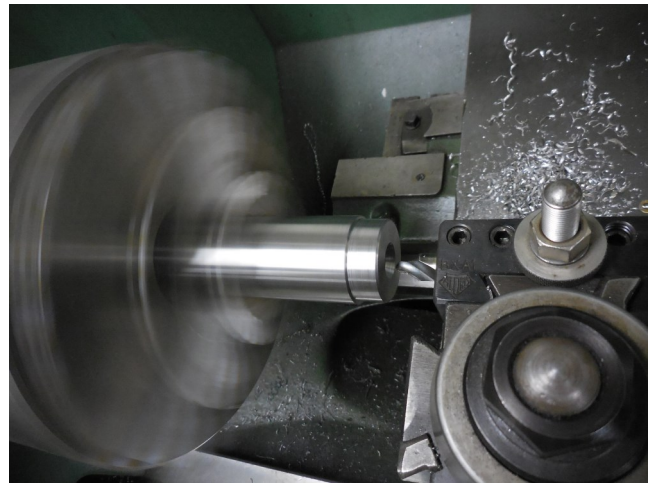

The out feed support I machined in one piece. I cut it into 2 pieces (2.625 stone side and 1.25 outfeed side). I machined the piece long to allow the two pieces to be machined to length after parting.

My key broach can only do 2.25" thick stock so I had to make the parts fit within this envelope.

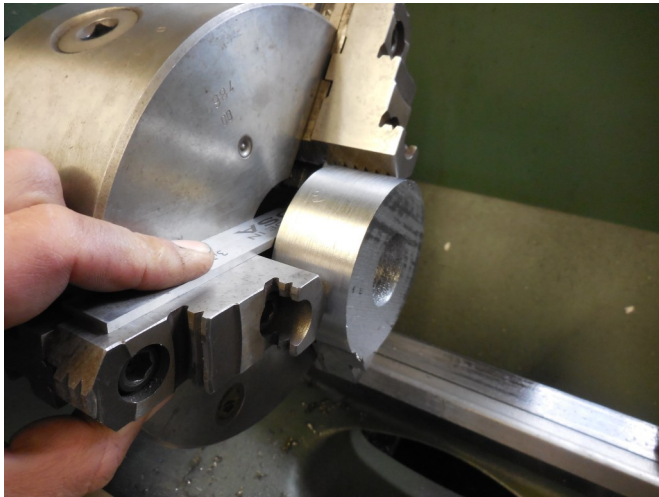

A trick to position thinner stock in the lathe jaw is to hold two parallels on a jaw while you are chucking the part. This will help to keep your part parallel to the chuck face.

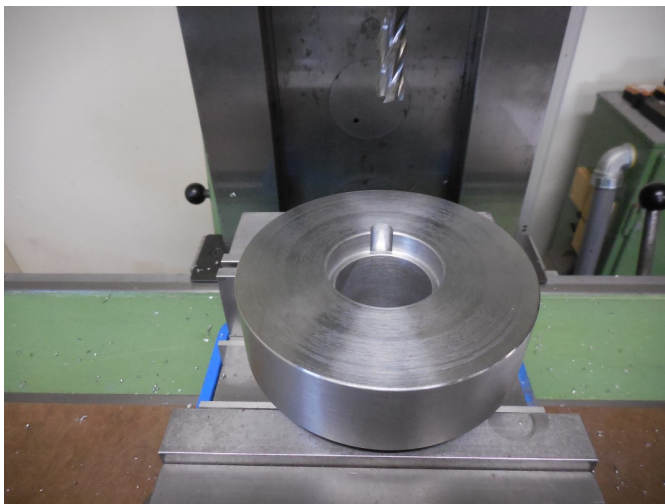

I milled a relief pocket so the keyway broach has adequate clearance. This is the face where the millstone drive lugs will be.



When broaching, use lots of oil, make sure the broach is not skewing. And have a plastic bucket to catch the broach so it doesn't fall and break when it hits something hard. Work carefully.



I used a parallel sitting on the key stock to project the angular alignment out. Then I used a gauge block to compare side to side and adjusted the part as needed. I put a 3/8-16 set screw opposite the key.

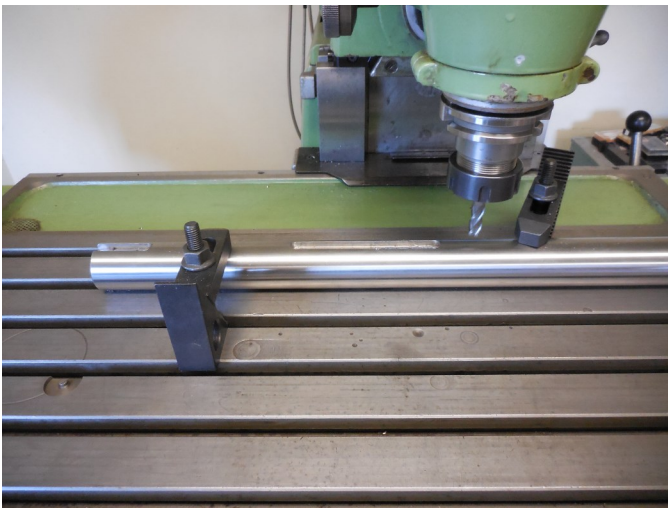

I used the "T" slots of the table to align the shaft with the x-axis travel of the machine. I held it in place with two clamps. I first cut the keyway for the drive pulley and the input side stone support.

My mill did not have enough travel to cut all three keyways in one setup.



I used my height gage to locate the one end of the keyway on the other end of the shaft.



To align the shaft so the keyways are in line with each other, I used a small magnetic sine bar set to 0 degrees. I used an indicator to align the top of the keyway parallel with the table.



I visually aligned the edge of the endmill with the mark from the height gage. I then cut the keyway.



To cut the stone holders for the main shaft I mounted it on a stub shaft held in a collet of my dividing head. I used the magnetic mini sine bar to align the keyway.

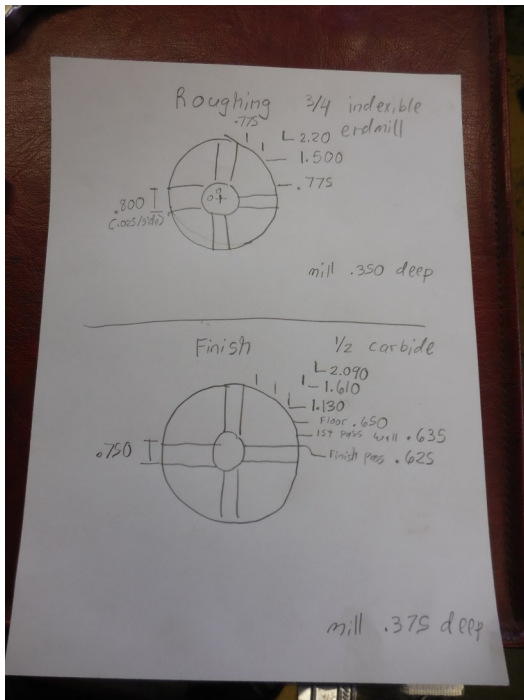

I roughed out the stone holder with a 3/4" indexable end mill.

I finished the part with a 1/2" solid carbide center cutter endmill. I calculated the different tool paths on this paper.

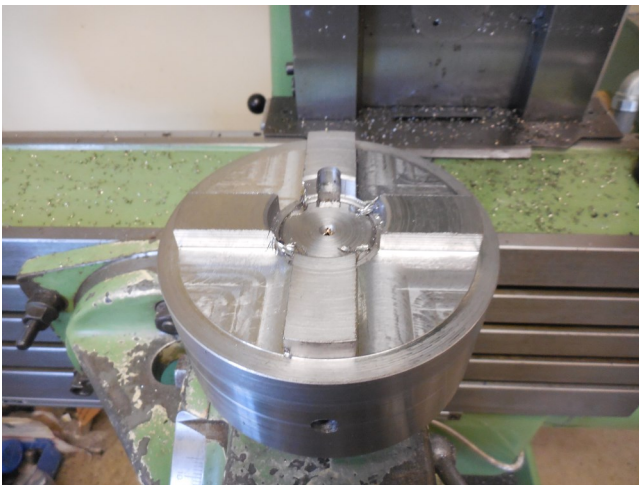

Here is the part after the roughing passes.

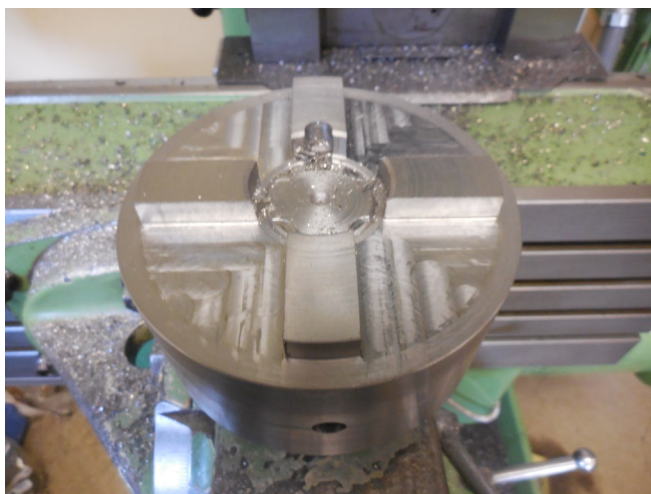

Here is the part after the finish milling passes. The output side (the first side milled) turned as the collet was not tight enough initially. I ended up milling the output side slightly under sized (which I made up with the plastic cushion piece).



To machine the plastic I used a sacrificial aluminum plate. I used a circle scriber to make the alignment of the blank easier.

To attach the plastic to machine the first side, I used the NYCCNC superglue trick. You can watch some videos on their YouTube channel for more information. You use the powder coating tape with 2P10 super glue with activator.

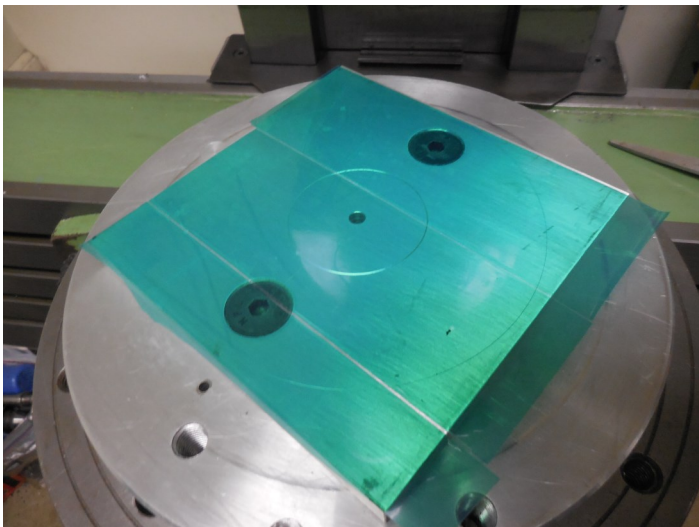

First, you put a layer of tape on the sacrificial plate.

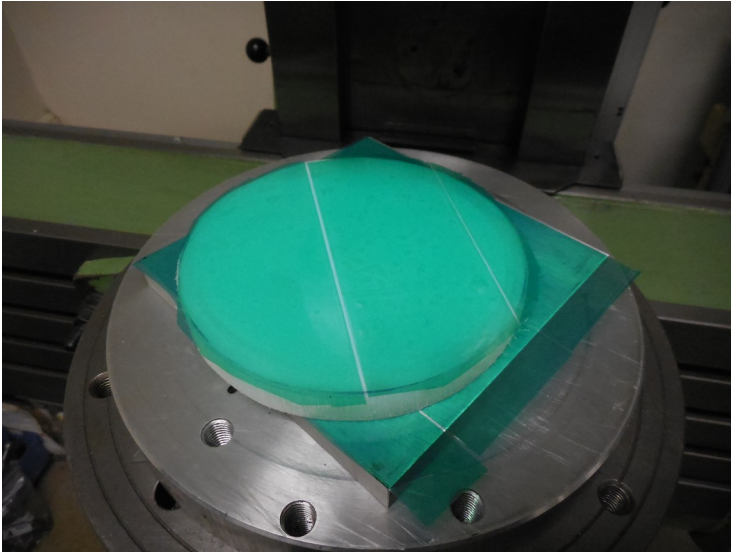

Then, put another layer of tape on the workpiece.

Put super glue down and then position your work piece. Spray with activator and within 30 seconds it is ready to mill. I gave it a couple of minutes for good measure.

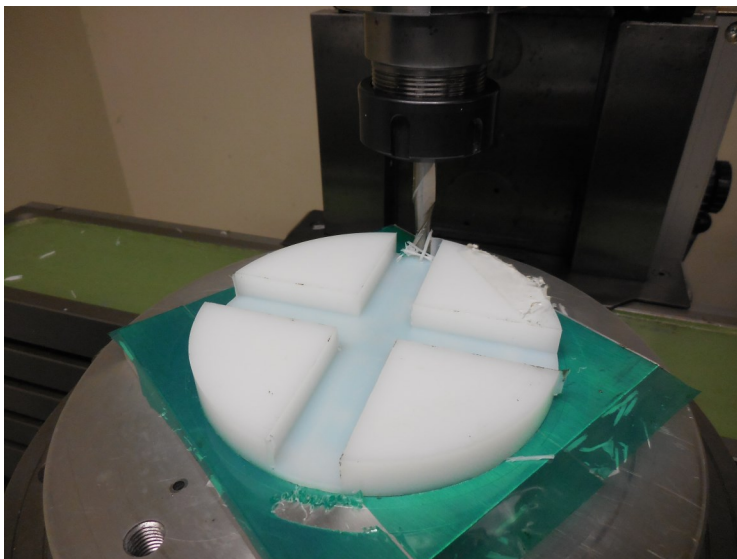
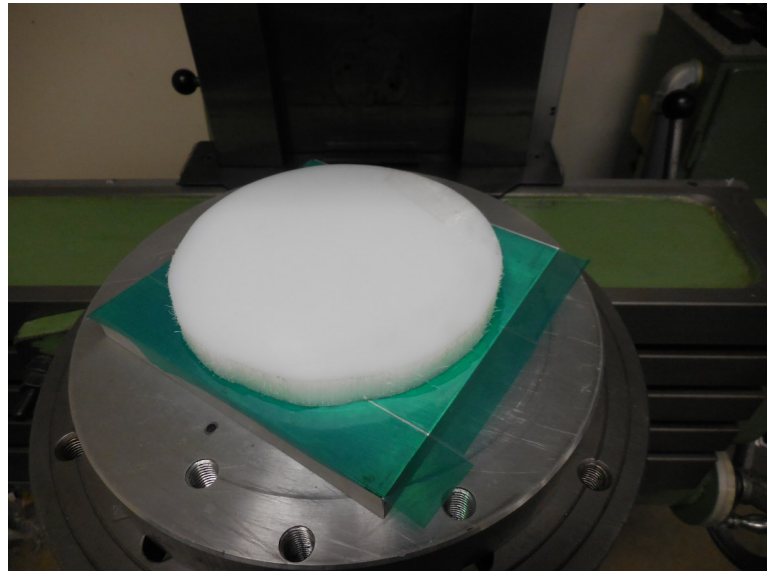

When milling the HDPE use a 2 flute high helix endmill that is for aluminum. The end mill must be sharp for good results.

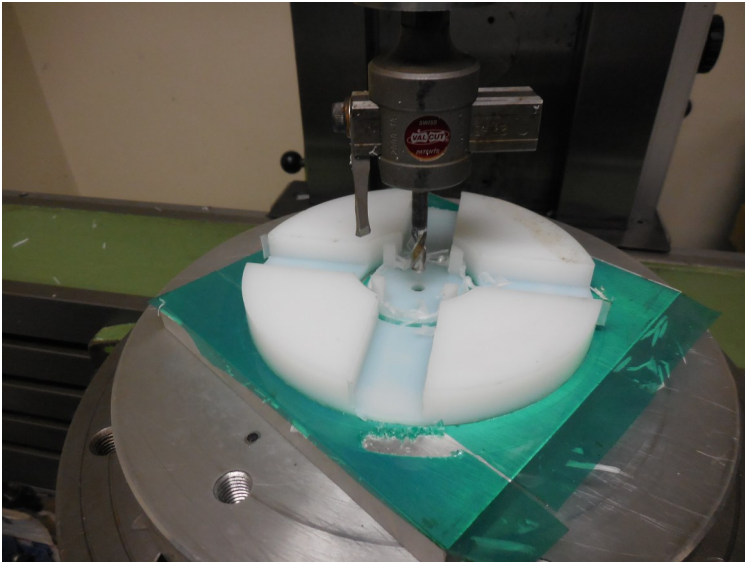

To cut the hole in the center I used a trepanning tool. You could also use a hole saw.

Because the millstone blank was cut by stone cutters and not machinists you need to determine the actual location, size and squareness of the slots. I set one slot square to the surface plate and made measurements from that. The slots were different sizes, off square and off center. I made allowances for this in how I cut the plastic pieces. I should have used bigger vee blocks but I didn't have any. The stone is the same granite as the Starrett surface plate.

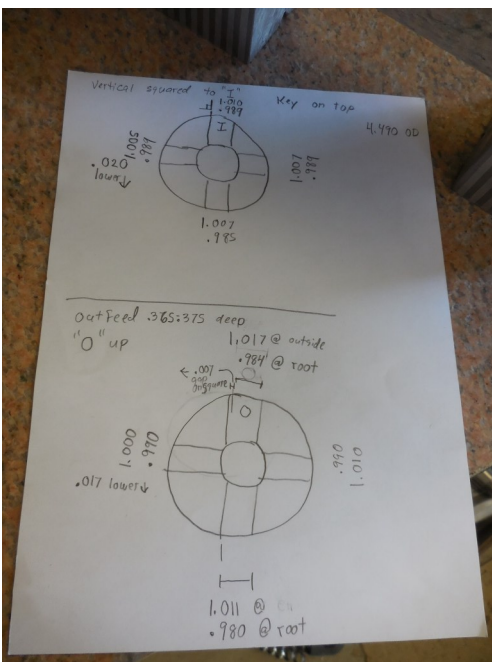
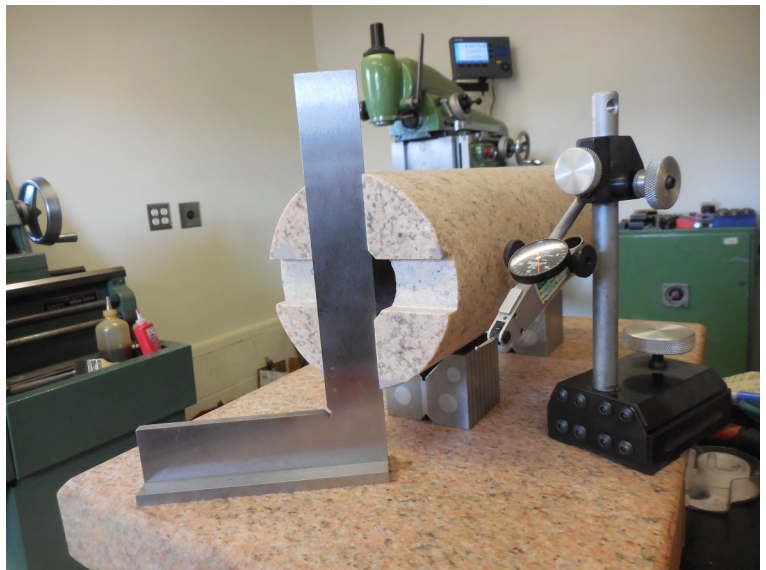

I made a sheet to keep all of the dimensions and angles for the slots straight. You need to think about it carefully and be sure you don't make the mirror image of what is needed.

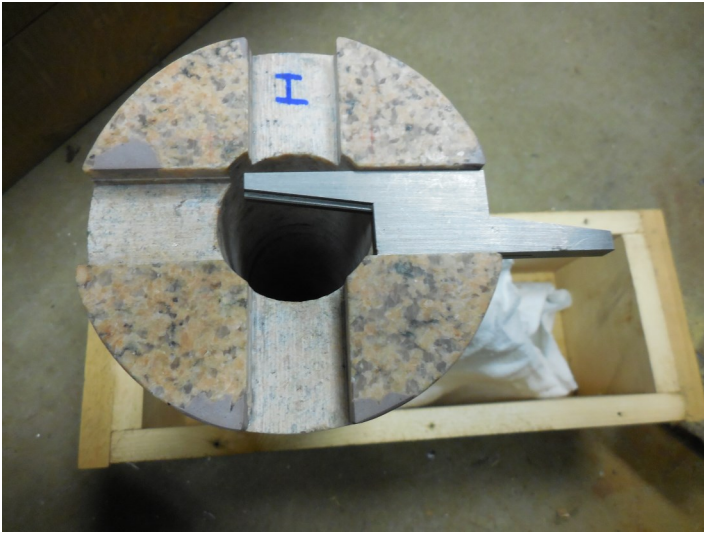

I checked the slot width with adjustable parallels. Just expand them till they fit and measure the size.

I attached the plastic directly to the end piece with super glue. Use acetone to clean the surfaces before supergluing. Also, super glue residue can be cleaned up with acetone. I put the piece in a container of acetone and let it sit for a couple of hours.

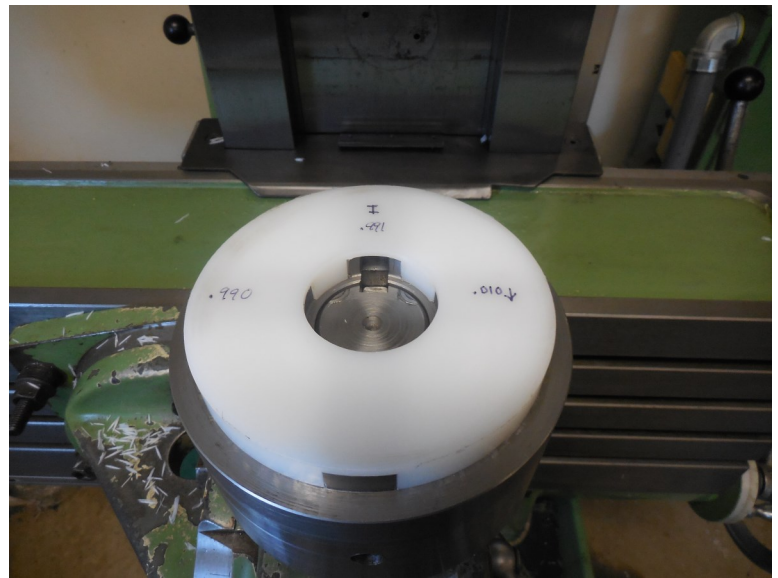

When I super glued the plastic on to mill the face I put the one large piece on top to make sure I had even flat pressure across the piece while the glue set.

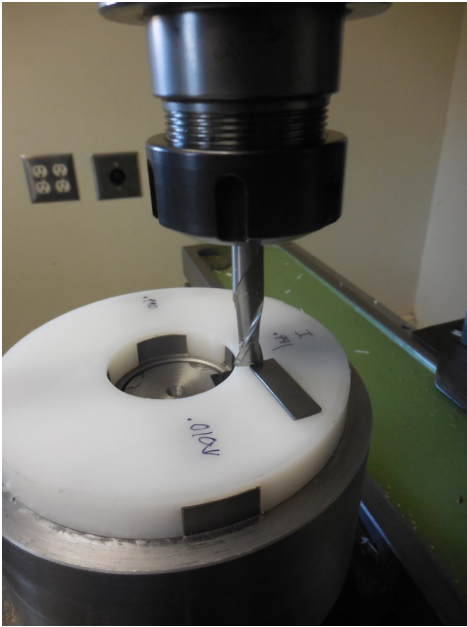

To set the Z axis height of my endmill I used a .050" gage block. I would set the cutter below the height of the gage block and raise the cutter slowly. When the gage block slipped under the cutter, I set the DRO for .050". You can also use a gage pin for this. Any size works just enter the size in the DRO once it will fit under the cutter.

After cutting the plastic I checked the fit with the millstone.



While the dividing head was still on the machine I turned it 90° and milled the relief for the furrows on the discharge end of the millstone.

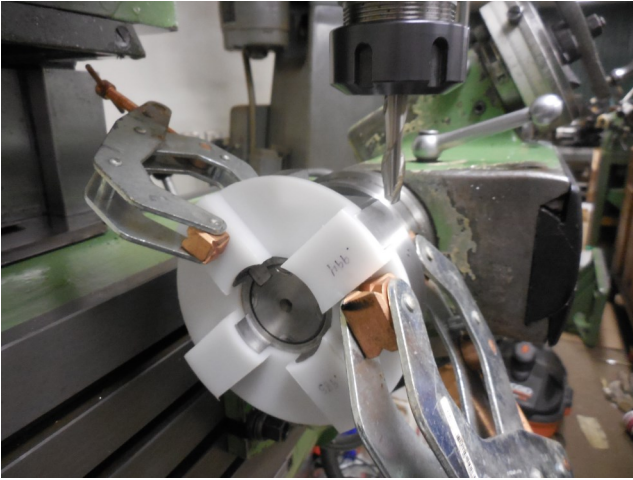

To machine the relief in the plastic piece I just held it on with some clamps and milled so the cutters rotation would hold the plastic piece against the metal back piece.

I rotated the piece 180° and cut the other side. Here is the finished piece with the clamps removed.

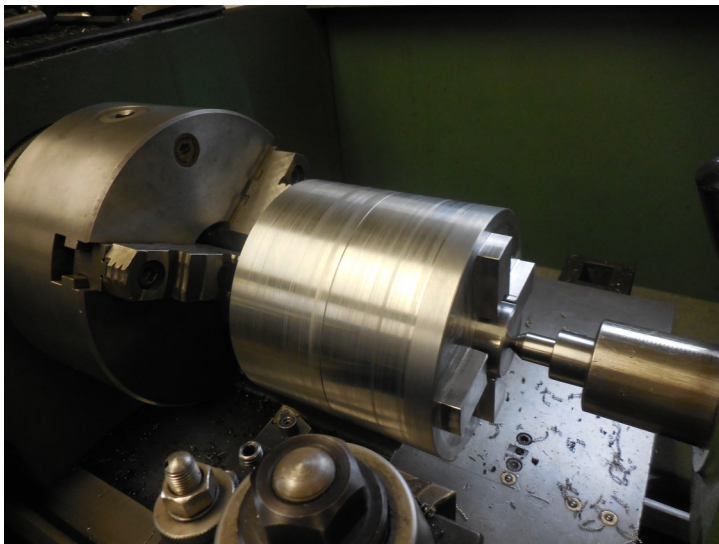

Because the bore through the feed screw piece is .0015" larger than the shaft to allow a sliding fit, when you tight the set screws it pulls the parts slightly off center. I put the pieces on a stub shaft and turned them to the finished OD. I had previously left some material just for this purpose.



The helical feed screw is a twin start 2.25" lead left hand screw. I used a spiral milling attachment on my machine. Some older horizontal milling machines had spiral, helical or lead attachments to enable them to do this type of work.

But don't worry if you don't have one. Modern VMCs (vertical machining centers) with a 4th axis can also do this and are quite common. Within 4 miles of my farm there are 2 shops with CNC machines capable of machining this feature.

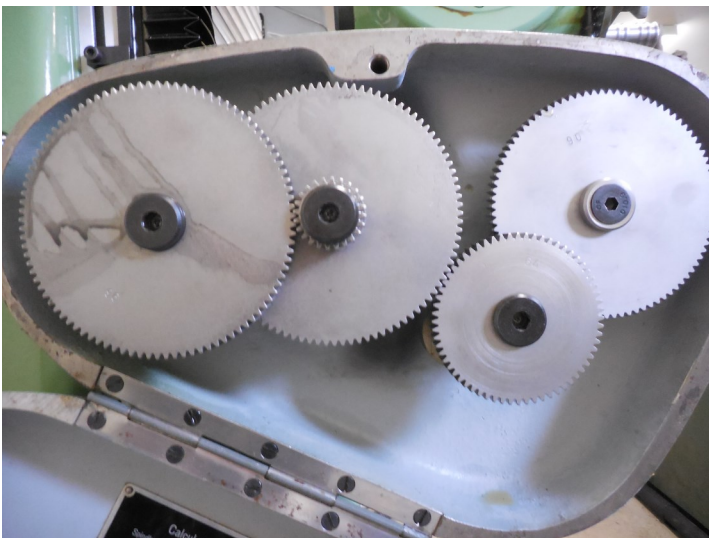

This attachment uses changeable gears to create a timed ratio of movement between the x-axis leadscrew of the machine and the work piece.

I started at one set screw (which I centered over so it would end up in the root of the furrow) and advanced to the next setscrew which I had conveniently positioned 2.25" away. As I went I made some sharpie marks of the path. In this way I was able to check that my lead and rotation were correct.

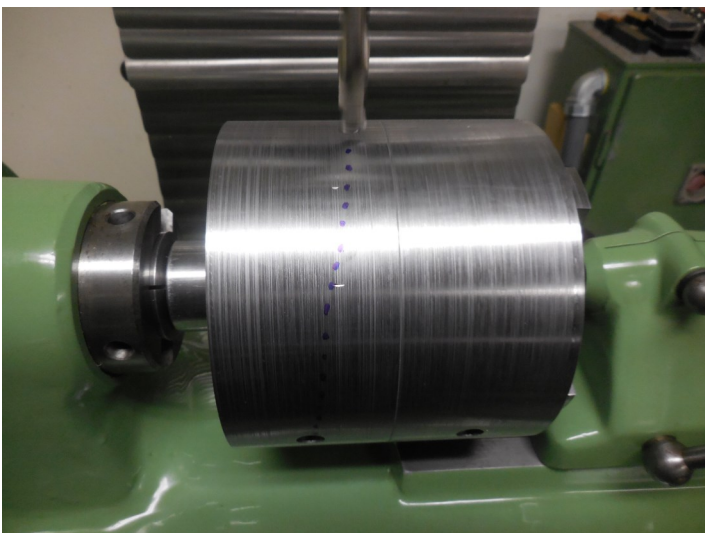

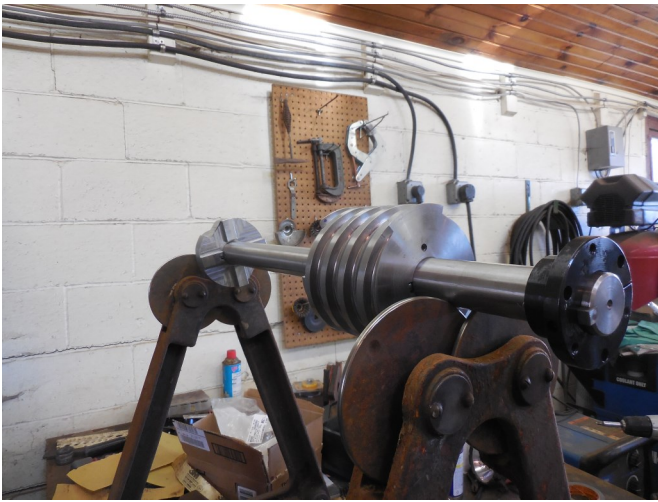

I first checked the balance of the machined components on the main shaft. When balancing the individual pieces I used half length key pieces in the empty keyways to not get false readings.

Many machine shops that do repair work have a balancer like this. Talk to them and see if you can borrow it for a couple of days.



To lay out the stone I used the plastic piece on the discharge side to locate the straight furrows and made 2 vertical lines 180° apart. I then marked two lines between these vertical lines so the stone was quartered. I used my height gage to mark the intersection points of the helical furrows with the 4 vertical lines.

Then I used a piece of plastic strapping to be a guide and drew the center lines of the helical furrows. On a piece of scrap I marked 3 lines representing the center and outside of the furrows. I repeated the process with the plastic strap and now my layout is complete.

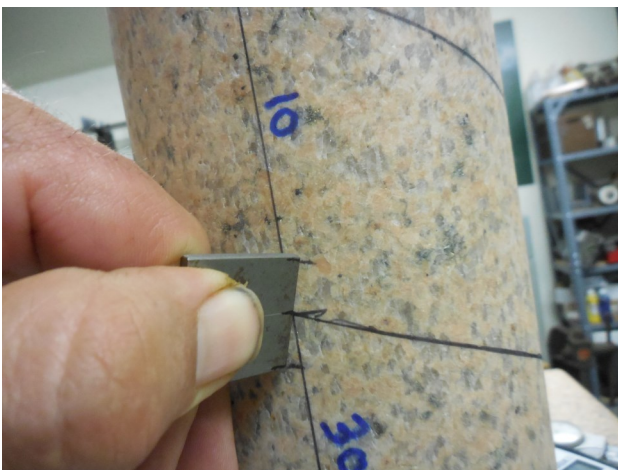



The tools I used to carve the millstone are a Trow & Holden 3/4B air hammer with a 9 point bushing tool (for roughing) and a 25 point bushing tool (for texturing the millstone). I used a 4 1/2" angle grinder with a diamond blade. I did most of the shaping with the angle grinder.



I got an old kitchen counter stone sample from my local lumber yard to practice carving and texturing.

I built a cradle from scrap 2x4's to hold the stone while I worked on it.





I marked the furrow center and edge sharpie layout marks lightly with the grinder. I then roughed in the furrows. I tapered the end of the furrow on the infeed side so I didn't chip the drive slots.





I used the 25 point bushing tool to texture the millstone. Be careful on the ends and along the axial furrow as the 90° corners easily chip.





Here are the components of the main shaft assembly.

Once I assembled the millstone on the main shaft, I balanced it. To do this, I turned it slowly letting go occasionally and saw where it would move to and stop repeatedly. I marked the low spot, removed a little material in that area and then rechecked it on the balancing stand. I repeated this process till there was no movement as I slowly turned it and let go to see if it would move. If the millstone is not adequately balanced there will be vibration when the machine is running.



Assembly and modifying parts:



The machine feet I purchased had 1/2" threaded attachments and my foot was only drilled for 3/8". I used my magnetic drill to open the holes up to 17/32" .

Supply chain issues meant that the Baldor motor I was going to buy had too long of a lead time. I ended up buying a WEG motor. Even though they are both 215T frame motors, the feet on the motor extended over the sliding mounting bolt holes. Since everything else is symmetrical. I drilled new holes from the other side to accommodate this motor.



Pick a socket is slightly smaller than the OD of your bearing. Use the socket to press the bearing into its holder.

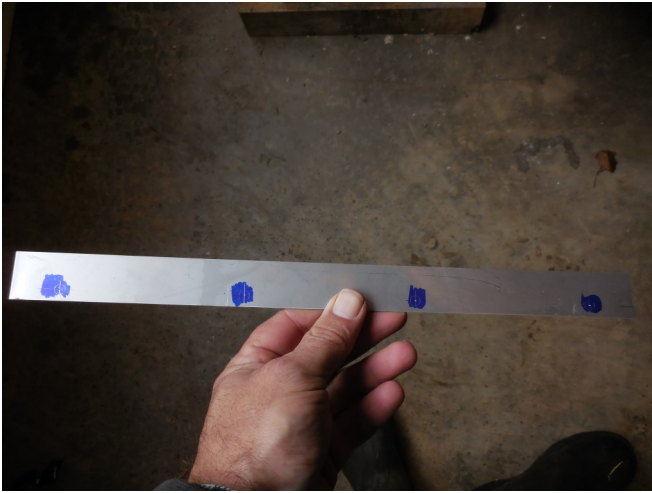

Since I was using perforated sheet, I made a hole location jig. It would be impossible to layout the perforated screen, this jig enabled me to locate the holes accurately.

I taped the jig in place and used the holes to locate the punch.

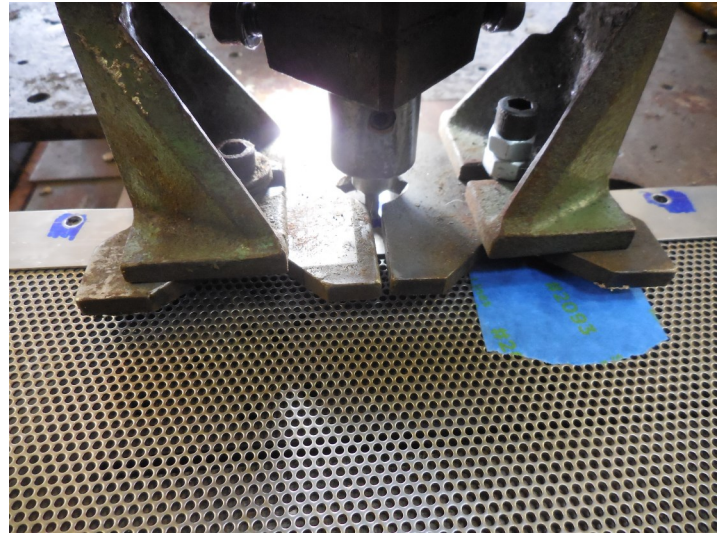

I used a slip roll to bend the screen. I bent a couple of test strips to get slip roll set correctly.



To bend the flats on either end I used a slapper to work the flat area.

I used the flat head cap screws to form the screen holes into the countersinks.

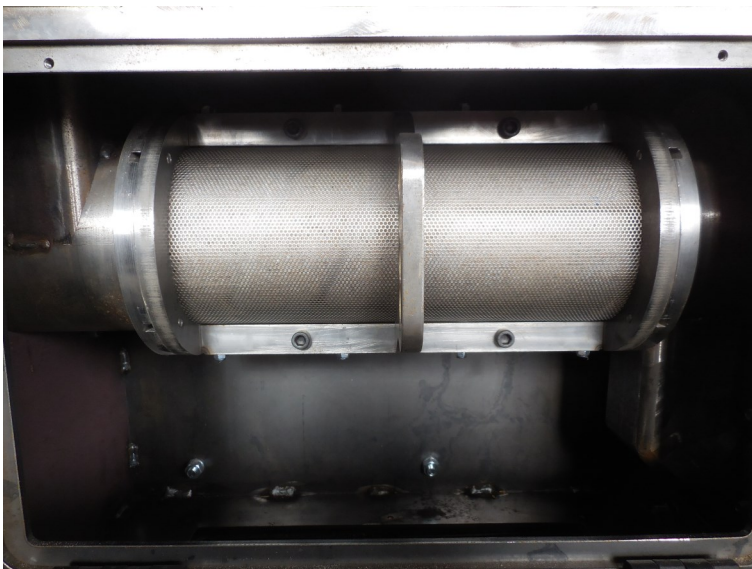
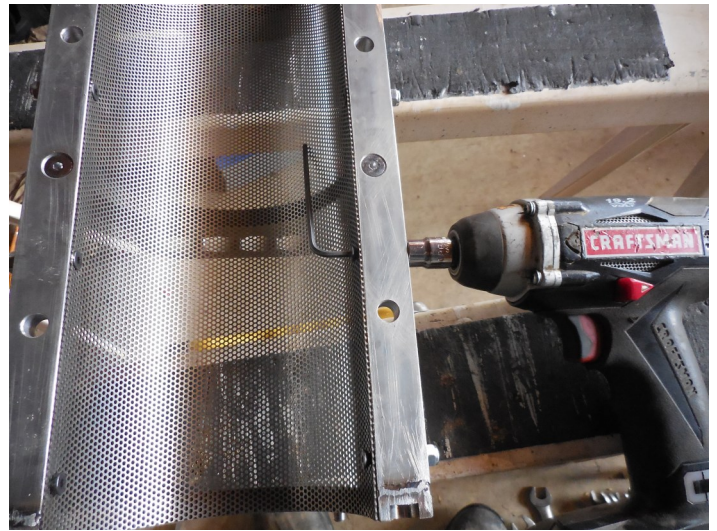

Here are the finished screens in the machine.

Pearling Machine Fasteners:

Main Shaft:

1x ½-12 x 1 ¼" FHSCS (flat head socket cap screw)

6x ¼-20 x 5/8" FHSCS

3x ¼-20 x 3/16 setscrews – key jack screws

2 x 3/8-16 x ¾" setscrews- output side

2x 3/8-16 x 1 ½" setscrews- input side

Base:

6x ½-13 x 3" bolt

1x ½ washer

6x ½-13 nuts (5 welded onto frame)

Motor:

4x 1/2-13 x 3 1/2" bolts + washers + nuts

4x 3/8-16 x 1 ½" bolt + washers, + lock washers + nuts

4x ½-13 nuts

Bearing holder:

4x ½-13 x 1 ¾ " FHSCS+ nyloc nuts

4x ½-13 x 1 ½" bolts + lock washers + nuts

Feed Rod:

4x 10-32 x ½ SHCS (socket head cap screw)

1/8" x 1" roll pin

Electrical Panel:

4x 7/16NC x 1" bolts + lock washers + nuts

Discharge Door:

8X 8-32 x 5/8" FHSCS

3x 6-32 x 1/4" setscrews

6x 3/8-16 x 1 1/4" + lockwashers + nuts

Dust Collector:

6x 1/4-28x 1/2" bolts + washers

Screen holder;

8- 1/4-28 x 3/4" FHSCS

16- 10-32 x 1 1/4" FHSCS + nyloc nuts

Purchased components used on this machine:

Input side bearing

4 bolt flange bearing MSC # 80463714

Output side bearing

Ball bearing 72mmOD, 35mm ID, 17mm wide McMaster-Carr # 5972K343

Door Handle Elesa # RG-1S.140-84

Door Hinge Elesa # CFM.60-45-SH-6

Door Hinge with integral switch Elesa # CFSQ.60-SH-6-F-A-D-5

Machine Feet MSC 4x # 86803335 (these are a 1/2 stud foot the design is for a 3/8" stud foot, either get the smaller stud feet or drill a larger hole in the mounting flange)

Pulleys and hubs

Motor side

5.6" sheave MSC # 82245390

1 3/8" Bushing MSC # 8224973

Machine Side

6.0" Sheave MSC # 82245374

1 1/2" Bushing MSC #82224932

Vee belts

B68 matched length vee belt McMaster-Carr 2x # 618K217

Brass Knob for adjustable weight

10-24 x 1" thread with brass knob McMaster-Carr # 512K61

Knob for feed gate

2" Star wheel MSC #76926039

Electrical

The page after the next page has the wiring diagram for the pearling machine. I am not an electrician or electrical engineer. You should review this design with your electrician and incorporate their suggestions into your build.

When I contacted my local electrical supply house for pricing for the components in this control panel build, I found out that many of the items were out of stock and had lead times of 2 weeks to 4 months. This long lead time is due to the current supply chain crisis. In a panic, I turned to eBay. I selected the "new" filter so I was only getting listings with unused stock that was most likely left over from projects. I got the components within a week and I saved 60% in the process.

These are the components I used:

Plug: Hubbel Twist lock HBL2721

Cord: 15' Sjoow

Strain relief:

3x Hubbel

1x Hubbel

Panel: Hoffman CSD16126

Panel Insert: Hoffman CP1612

Fuse Block: 3 pole Gould Shawmut 20313 (for Class H/K Fuses)

Main fuses: 3x FRN-R-30

Contactors: Allen Bradley 100-C30*00

Overload Protection Relay: Allen Bradley 193-EEED

Current transformer (for Ammeter) : PC&S 546-60-L48

Ammeter: PC&S ST955A30A

Transformer fuse block: 3 pole Gould Shawmut 30350 (for class CC fuses)

Transformer fuses:

Input: 2x FNQ-R-6/10

Output (control voltage): 1X FNQ-R-8/10

Transformer(0.05 KVA 240/480 to 120v): GE 9T58K0042

Electrical components continued:

Terminal strip (4-circuit): Ideal 89-404

Start Button: Allen Bradley 800T-A1A

Start Legend Plate: Allen Bradley 800T-X547

Stop Button: Allen Bradley 800T-A6A

Stop Legend Plate: Allen Bradley 800T-X550

Motor: WEG 010118ET3E215T-W22

Originally I was going to use a Baldor EM3774T but it had a minimum 8 week lead time so I went with the WEG motor.

Here are the pertinent specs for the motor:

230/460v 3 \emptyset

10HP

Frame 215T

1800 rpm

These components can be substituted for different brands depending on what your local supply houses carry or your electrician prefers to use.

It is a good idea to get extra fuses and keep them in a Ziploc bag on the bottom of the inside of the control panel. This is something I have started doing and it minimizes down time (especially now when these fuses have a 2-7 week lead time).

230V 3Ø 30A

Power In

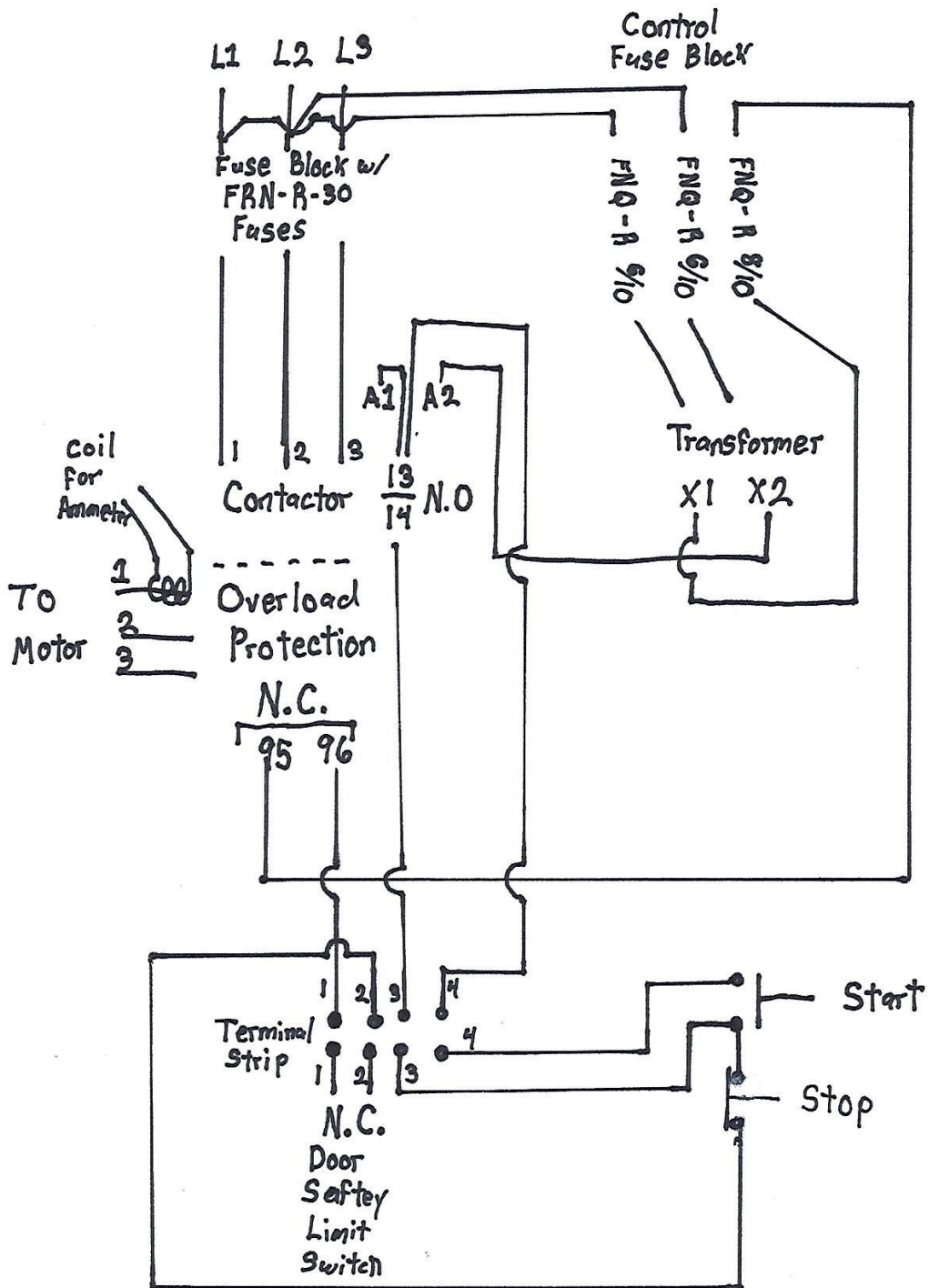



I laid out the components on the insert panel. I marked the mounting hole locations. I then put pieces of tape with the component name and the screw size I wanted to use. Then I drilled and tapped the mounting holes.

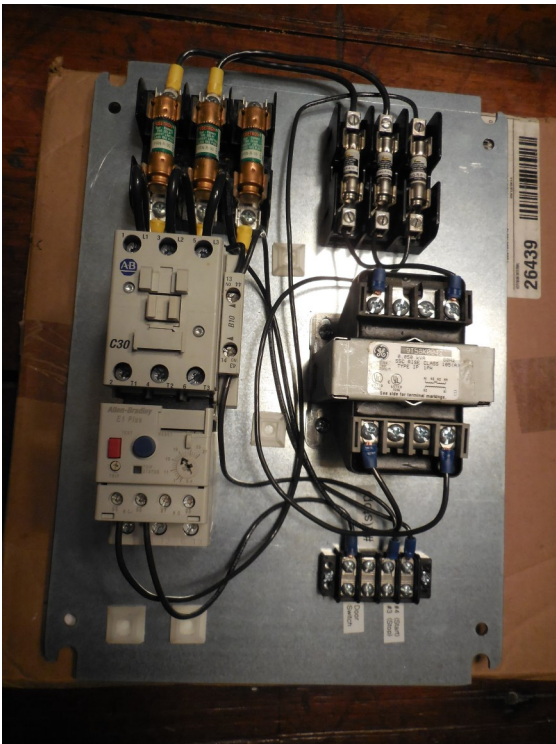

Here is the assembled and wired subpanel for the electrical panel.

When drilling holes into the electrical panel, put painters tape around the holes to protect the paint from scratches.

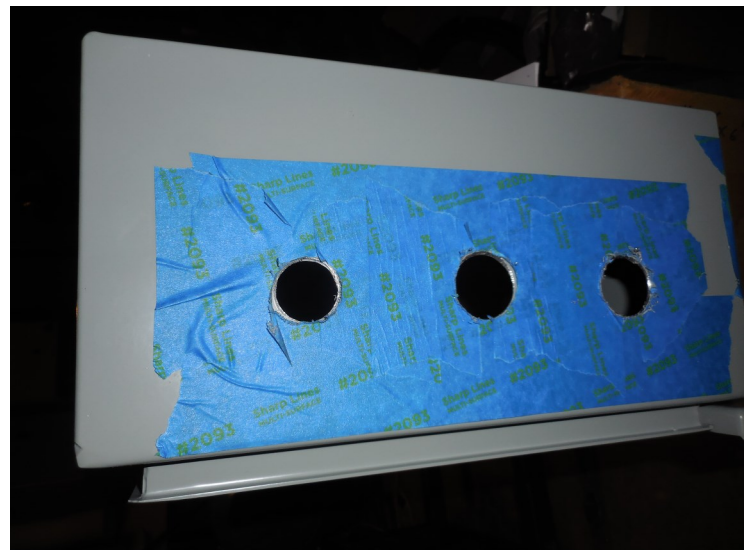

Potential Modifications for your Pearling Machine:

As this is a prototype, some things are naturally overly complex. If this were to become a production item over several generations, some things would be simplified and features might be added or subtracted. After building the machine here are couple of things that could be simplified.

When I was designing this machine in CAD, I wanted all of the controls to be in the same area. But as this machine is not too large some of the controls can be moved slightly with little ill affect to the machines operation and simplify its construction.

- The buttons and gauge on the control panel could be installed in the front face of the electrical panel.

- The feed gate could have a right angle bend down on the end and a knob with a threaded rod going into the infeed tube could be used to open and close the feed gate precisely.

I wanted the screens to be easily changed by one person. I think my design works well in this respect. But if you wanted to forgo the complex track that the screen holders run in, you could move the electrical panel and have a door on each side. The screen holders would have a lug where a bolt would attach them to the ends and the screens would still have 4 bolts holding them together. However, this design while simpler might require 2 people to change the screens.

There are two designs for horizontal millstone pearling machines. I used the design where the last 3rd had straight axial furrows. There is another design where the spiral furrows taper and the last the 1/3 of the millstone has no furrows. The axial furrows had some build up of milling residue which means they were not actively working to pearl the grain. If I were to make another millstone I would try one where the last 3rd didn't have any furrows.

Dust collection: Dust accumulates in the corners of the bottom of the machine. If you had 1/8" x1" wide slots in the corners it would make jets which would help keep this clean. The sideways jets should be higher than the lengthwise jets to keep the airflows from working against each other.

Changes I am planning to make to my pearling machine:

The discharge door does not work as intended. I have to manually open and close it to keep the motor in the correct amperage range (15-22amps). There are two potential issues.

The first issue is that the discharge chute should be at an angle. I am going to cut the side pieces on the existing chute so I can bend the chute up and down to find the optimum angle. Once I know the best operating angle, I am going to fabricate a new chute.

The discharge door is too heavy. I am going to fabricate a new door out of 16ga steel. I am also going to make a new smaller adjustable weight for the door. The machine builds pressure and pushes the door open but the amperage draw often gets too high. The design just needs to be tweaked so that it works correctly.

Because of time constraints I used 0.078" perforated metal for the screens to get the machine operational. This screen does work and was easy to fabricate. Traditionally a slotted hole is used on the screens. I purchased slotted punches and plan to make screens with slotted holes.

I plan on painting the machine. The weather in December when I finished the machine was too cool to ensure that the paint would cure correctly. So, I will sand blast the parts and paint them in the spring.

I also need to design a belt guard for the belt. Feel free to contact me for the plans of my belt guard design.

Operating the machine:

For the tests I carried out, I had the feed gate 7/16" open which is a feed rate of 9.5lbs per minute (570lbs/hr) or 50% of the machines theoretical capacity. The theoretical capacity of the machine is 19lbs/min (1,040lbs/hr) which is a 5/8" feed gate opening. I manually adjusted the discharge door to keep the motor's amperage draw between 15-22amps. The machine is not really working until the chamber is loaded up and the motor is seeing an increased load.

I plan on tweaking the design of the discharge door to get it working so that the machine can run without constant supervision. Check with me on the latest discharge door design before beginning your build.

The different grains I pearled had a moistures between 12.4 - 13.3%. When pearling the grain gets up to 130°F and can start to sweat. I think that putting the grain in a cloth bag when it comes out of the pearling machine would be a good idea so it can sweat off and the moisture doesn't cause any issues. I plan to experiment with this. Also because I was pressed for time I did the pearling passes one after another. I think it would be a good Idea to let the grain set and cool off between passes. Small scale artisanal pearling is something completely new in North America so I will need to experiment and develop a process.

Pearling for Vomitoxin Reduction

I used the pearling machine to explore the possibility of reducing vomitoxin in small grains. My advisor Elizabeth Dyck helped me secure some high vomitoxin samples. These were cleanings from grain that had had a special cleaning process to reduce vomitoxin in the grain but the cleanings were high vomitoxin. Before starting I took a baseline sample. About 1/3 of the way through each pass I took sample A and 2/3 of the way through I took sample B. I ran the grain through the machine 3 times. There is a definite reduction in vomitoxin. Possibly a 4th run would be merited. Further testing is needed to figure out the best methods for vomitoxin reduction.

Rye

Vomitoxin ppm	Test Identification
2.5	Rye Baseline
0.9	Rye 1A
1.2	Rye1B
1.6	Rye 2A
1.3	Rye 2B
1.3	Rye 3A
0.9	Rye 3B

Hard Red Spring Wheat

Vomitoxin ppm	Test Identification
6.5	HRSW Baseline
4.1	HRSW 1A
2.7	HRSW 1B
3.0	HRSW 2A
2.7	HRSW 2B
1.1	HRSW 3A
1.1	HRSW 3B

Pearled Wheat Products

In Europe you will often see lightly pearled grain especially in organic or health food stores. The advantage of lightly pearling grain is that it reduces cooking time.

Here are the names for some pearled products.

Grain	Lightly Pearled	Full Pearled
Barley	Pot Barley	Pearled Barley
Emmer	Faro Medio (common Faro)	
Spelt	Faro Grande	
Einkorn	Faro Piccolo	
Wheat		Frumenty

Cooking times of pearled wheat was not part of the grant. Below is my plan for checking cooking times.

Wheat berries:

1pass wheat:

2 pass wheat:

3 pass wheat: (I am calling this full pearl but maybe a 4th pass would be needed for true full pearl grain)