

S441
.S855

S U S T A I N A B L E A G R I C U L T U R E

John Jemison
Extension Water Quality Specialist

Chris Jones
Agronomist, Natural Resources Conservation Service

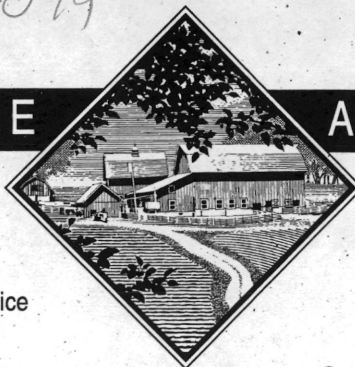

Watering Systems for Livestock

University of Maine Cooperative Extension Bulletin #7129

A consistent supply of high-quality water is vital for livestock. Since it is no longer appropriate to allow livestock access to streams, many livestock producers are installing watering systems.

Watering systems create many opportunities such as:

- ◆ *increased livestock productivity*
- ◆ *improved nutrient distribution*
- ◆ *protection of stream and pond water quality*

If you have water in each paddock, your livestock will eat more feed because they are not resting in the water or traveling to and from water. Greater feed intake means increased weight gain and/or milk production. Animals kept out of surface water also have less risk of mastitis.

Secondly, if animals stay in paddocks, the nutrients in the urine and feces replace nutrients removed in the forage. Otherwise, the nutrients and bacteria in manure may degrade water quality. In coastal zones, bacteria can lead to closed shellfish beds, and excess nitrogen and phosphorus can contribute to algal blooms in estuaries and lakes.

Why is Water Important to Animals?

Water is an essential fluid for animals. It is a key component in cells, and comprises between 40 to 80 percent of the body weight of livestock, depending on species and age of the animal. It is the main way nutrients move through and are excreted by the animal. Water helps control temperature, cushions joints, supports fetuses and has many other crucial functions.

An animal can live without food much longer than it can live without water. When water is lacking, productivity becomes greatly diminished. Weight gain slows, animals become lazy and seek shade, blood thickens, toxins accumulate and, ultimately, if deprived of water long enough, animals will die.

Sources of Water

Animals get most of their fluids from drinking water. Many factors influence how much they need, including species, size, age, body weight, weather, and water quality. Table 1 (page 2) shows the maximum amounts of water needed by different animals.

Do animals require as high-quality water as humans? No. Animals can drink poorer quality water, but only to a point. For example, animals can drink water that contains some bacteria. There are drinking water standards for livestock, just as there are for humans. For instance, the drinking water standard for nitrate (N) is 100 parts per million (ppm) for livestock but only 10 ppm for humans.

Animals perform better on high-quality water. Try to supply the highest quality water possible to animals whether in the barn or on pasture. Keep drinking troughs as clean as possible. It will make a difference.

Table 1. Maximum Livestock Water Requirements

Livestock	Gallons/Head/Day
Beef Cattle or Horses	12 to 15
Lactating Dairy Cows	40
Sheep	2
Hogs	4

Management Intensive Grazing

A ready supply of good quality water is important to maximize the efficiency of grazing systems. A watering system can bring water to each paddock so that your grazing animals have water to meet their metabolic needs. There are several types of watering systems, including quick-move systems, pasture pumps, ram pumps, sling pumps and solar pumps. Each system has strengths and weaknesses, and cost varies greatly. We will discuss each system here.

Quick-Move systems: Quick-move systems are designed to provide water to animals from a powered or pressurized water source. Water sources used in quick-move systems include water from drilled or dug wells, lakes, streams or other water sources. In some cases, water from these sources can be gravity-fed to individual paddocks.

A quick-move system is comprised of the following components:

- ◆ plastic tubing to move water from the source to each paddock
- ◆ quick-disconnect couplings
- ◆ watering troughs
- ◆ float valve to govern water refill into the tub

The cost of a quick-move system can be relatively low, depending upon a number of factors. The main factor is the size of the system (feet of pipe, number of couplings to bring water into paddocks, number of troughs, and cost to pump water). There are advantages to these systems. You can provide plenty of clean water to your animals in each paddock. When you move the tub, water is dumped out and the trough is cleaned (compared to a system where the animals drink out of a fixed trough somewhere on the farm).

One consideration you need to make is the size of an individual trough. If you have a number of animals drinking at once, you need to make sure the supply can equal the demand. One small tub may not be sufficient. Once a quick-move tub is emptied, it can be easily pushed around and not function properly. Figure 1 below shows an example of a quick-move watering system.

This type of system has other advantages, including ease of setup and breakdown, several animals can drink at once, and placement of tubs anywhere within a paddock. The only real disadvantages to this system are replacement costs if couplings get broken or if pipe is trampled. If your water is coming from a consistent water source, the system is virtually fool-proof.

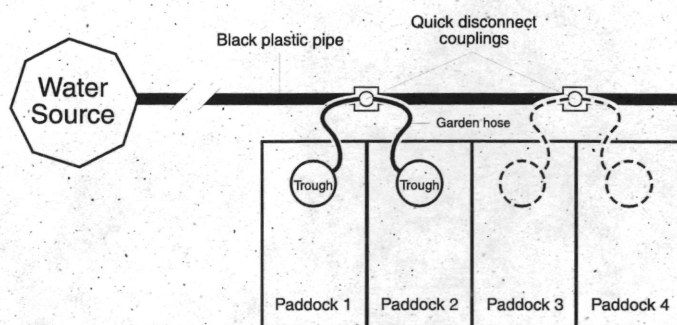

Figure 1. Setup of a quick-move watering system. Note that one coupling (on plastic pipe) can serve two or more paddocks.

Many people will employ a quick-move watering system in conjunction with another watering device, such as a ram pump. In this case, the ram pump would pump water to the highest place on the landscape to be stored in some type of water-holding device, and then water is fed by gravity to each paddock using a quick-move system. Some combination of these will enable you to bring water to individual paddocks.

Pasture Pumps: Pasture pumps are animal-powered pumps that can provide water to larger livestock. These pumps operate by the animal pushing a lever with its nose, which pumps water from the source to a bowl beneath the lever. Each stroke produces about a pint of water delivered to the bowl. Generally, one pump is required for every 30 animals. These pumps deliver water from ponds, streams, dug wells or other water sources. The advantages to these pumps are as follows:

- ◆ no special water requirements are needed
- ◆ relatively low cost
- ◆ very dependable and low maintenance
- ◆ easy to set up
- ◆ mobile
- ◆ work well in a variety of situations

Pasture pump systems do have a few disadvantages. These include:

- ◆ only one animal drinks at a time
- ◆ a large system may need several pumps
- ◆ shallow water sources may run dry
- ◆ weight of pumps makes moving them around difficult
- ◆ limitations due to height water must be pumped (pasture pumps are limited)

However, pasture pumps can play a nice backup role in a watering system. If your normal water source is not available, you can employ a pasture pump for a short period of time. It is better than allowing animals into a stream.

Ram Pumps: The key to using a ram pump on a farm to provide water to livestock is that you must have a drop in elevation to create the energy to drive the pump. The elevation drop can be created by a small waterfall or an elevated pond. For each one foot drop in elevation, a ram pump can pump water up 10 feet. It is possible for this system to deliver water to the highest point on the landscape, then gravity-feed it into each paddock using a quick-move system.

This is very old technology. First developed in 1775, this watering system has provided water to livestock without fossil fuel or electric power for over two centuries. Two and three-inch pumps are available, depending on the volume of water needed, how high the water must be pumped, and how far the water must be moved. If water must be moved a long way, the larger pump is recommended.

To understand how this pump functions, look at Figure 2.

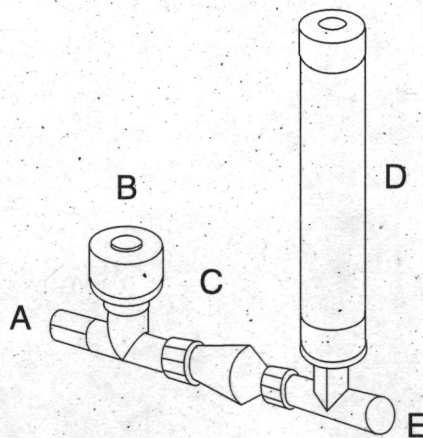

Figure 2. Key features of a ram pump. This pump works by having water move into the pump from point A through B and C. There is a rubber bladder in D that compresses as the water rushes in. As the bladder expands, a valve in B blocks the water from moving backwards, forcing it through area E. A cyclical pattern is established so that water flow to the water storage area is constant.

There are numerous advantages to using a ram pump:

- ◆ relatively inexpensive compared to other sources
- ◆ flexible (pump water to one trough or to a quick-move system)
- ◆ one system can supply water for large number of livestock
- ◆ little maintenance required

There are a few disadvantages to this system, including:

- ◆ must have some drop in elevation to drive the pump
- ◆ sometimes, pump will stop for no apparent reason. Pumps can run well for months. However, the disadvantages may outweigh the advantages.
- ◆ high water flows (floods) may disrupt system
- ◆ there is some overflow water (waste water that does not go up the plastic pipe) that must be dealt with (if in river, no real problem, more a problem in ponds)
- ◆ annual set up and take down can be time consuming

Sling Pumps: Sling pumps require flowing water for power. A sling pump is a cone-shaped pump that is attached to the bottom of a stream. Stream current spins propellers, driving water through plastic pipe to a point that is accessible to cattle. These are fairly expensive (\$800 to \$1,200), and you must have flowing water to drive the propellers. They are easy to set up, but there are limits to how high and how far water can be pumped.

Solar Pumps: Solar technology is probably the newest and potentially the most flexible of all the watering systems. It is probably also the most expensive. Solar pumps work by having photovoltaic cells capture light energy and transfer that energy to a pump which pushes water great distances and to great heights. Price vary from \$750 dollars (do-it-yourself) to \$4,000 for a system that has battery backup for cloudy days. To assemble a system yourself, we recommend you have some experience in wiring.

Solar pumps work well in conjunction with quick-move systems. Water can be pumped up to storage on the highest point on the landscape, and then it can be fed by gravity to individual paddocks. If you don't want to have battery recharge, you also need to have enough storage for cloudy days. These systems can produce large amounts of water (over three gallons/minute) for large livestock systems.

Conclusions

There are many possible watering options. Watering systems are the wave of the future. Keeping livestock out of streams is considered a best management practice in most states. From the production side, you'll get the highest efficiency if you keep livestock in paddocks with quality forage and a good water supply.

There are many things to consider when you select a system for use on your farm. The most important is to look at water demand and make sure that the system can meet your needs. Contact your county Cooperative Extension office for more information on setting up a watering system for you.



UNIVERSITY OF
MAINE
Cooperative Extension

This fact sheet was produced by the Northeast Region Sustainable Agriculture Research and Education (SARE) group in cooperation with the University of Maine Cooperative Extension and was funded by a grant from USDA-SARE.



Published and distributed in furtherance of Acts of Congress of May 8 and June 30, 1914, by the University of Maine Cooperative Extension, the Land Grant University of the state of Maine and the U.S. Department of Agriculture cooperating. Cooperative Extension and other agencies of the U.S.D.A. provide equal opportunities in programs and employment. 10/97

Printed on recycled paper.