



US011597687B2

(12) **United States Patent**
Scott et al.

(10) **Patent No.:** **US 11,597,687 B2**

(45) **Date of Patent:** **Mar. 7, 2023**

(54) **BULK ANIMAL BEDDING**

(71) Applicant: **PittMoss, LLC**, Ambridge, PA (US)

(72) Inventors: **Brian Scott**, Ambridge, PA (US);
Charles Lee Bethke, Williamston, MI (US); **Mark David Goldman**, Sewickley, PA (US)

(73) Assignee: **PittMoss, LLC**, Ambridge, PA (US)

(*) Notice: Subject to any disclaimer, the term of this patent is extended or adjusted under 35 U.S.C. 154(b) by 0 days.

(21) Appl. No.: **17/678,811**

(22) Filed: **Feb. 23, 2022**

(65) **Prior Publication Data**

US 2022/0177382 A1 Jun. 9, 2022

Related U.S. Application Data

(63) Continuation-in-part of application No. 17/521,022, filed on Nov. 8, 2021, which is a continuation of application No. 14/856,663, filed on Sep. 17, 2015.

(60) Provisional application No. 62/060,911, filed on Oct. 7, 2014.

(51) **Int. Cl.**
C05F 11/00 (2006.01)
C05G 5/12 (2020.01)
A01K 1/015 (2006.01)

(52) **U.S. Cl.**
CPC **C05F 11/00** (2013.01); **A01K 1/015** (2013.01); **A01K 1/0154** (2013.01); **A01K 1/0155** (2013.01); **C05G 5/12** (2020.02)

(58) **Field of Classification Search**

None

See application file for complete search history.

(56) **References Cited**

U.S. PATENT DOCUMENTS

3,876,411 A	4/1975	Fowler	
4,067,140 A	1/1978	Thomas	
4,123,489 A	10/1978	Kelley	
4,221,749 A	9/1980	Dedolph	
4,297,810 A	11/1981	Hansford	
4,357,780 A	11/1982	Ball	
4,414,776 A	11/1983	Ball	
4,932,156 A	6/1990	Underwood	
5,456,733 A	10/1995	Handley	
5,647,665 A	7/1997	Schular	
5,653,053 A	8/1997	Handley	
5,738,703 A	4/1998	Bandurski	
6,076,299 A	6/2000	Spittle et al.	
2011/0014425 A1*	1/2011	Wirz	B27N 3/00 427/209
2012/0000428 A1*	1/2012	Keating	A01K 1/0107 119/28.5
2012/0000620 A1*	1/2012	Keating	D21C 1/02 162/68
2012/0285384 A1*	11/2012	Boote	A01K 1/0155 264/109
2013/0095559 A1*	4/2013	McIntyre	B01J 20/28033 435/262.5

(Continued)

Primary Examiner — Wayne A Langel

(74) *Attorney, Agent, or Firm* — Jonathan M. D'Silva; MMI Intellectual Property

(57) **ABSTRACT**

A bulk animal bedding material is presented comprising shredded and fiberized natural lignocellulosic material vigorously blended with a solvent and small grain particles (SGPs) to form twisted, curled, clumped, and rolled fibers with the SGPs integrated within and/or encasing said fibers.

9 Claims, 9 Drawing Sheets

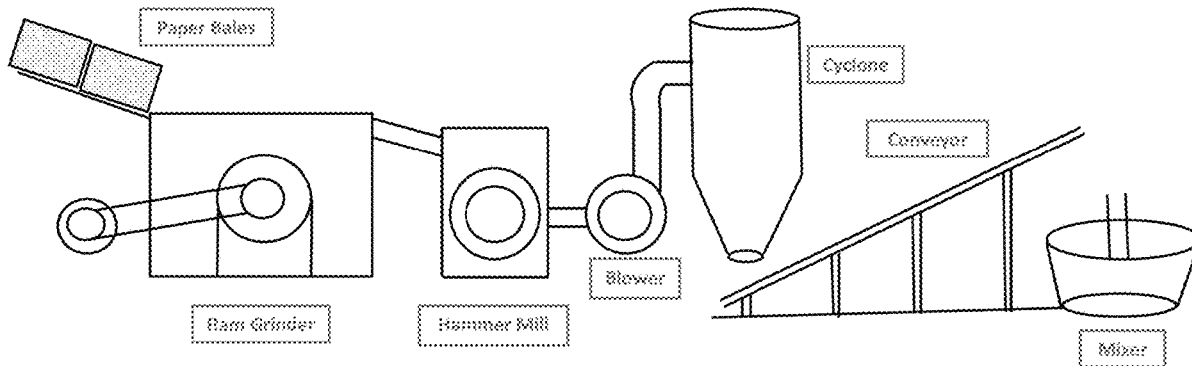

(56)

References Cited

U.S. PATENT DOCUMENTS

2013/0126781	A1*	5/2013	Boote	A01K 1/0155	252/184
2014/0373791	A1*	12/2014	Boote	A01K 1/0152	119/171
2015/0017118	A1*	1/2015	Tsengas	A01K 15/024	119/28.5
2021/0352868	A1*	11/2021	Boote	A01K 1/0155	
2022/0055959	A1*	2/2022	Handley	C05G 5/12	

* cited by examiner

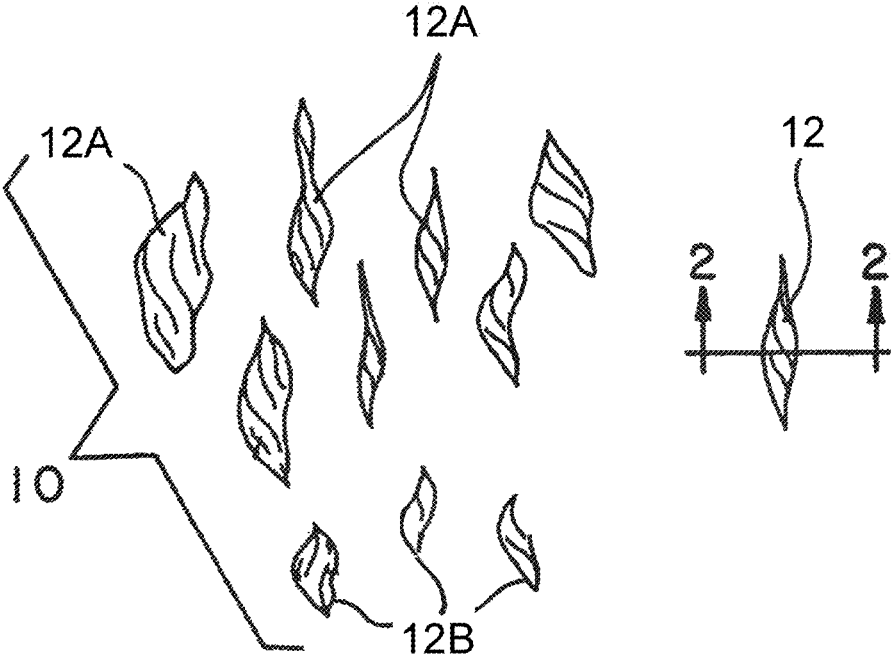

FIG. 1

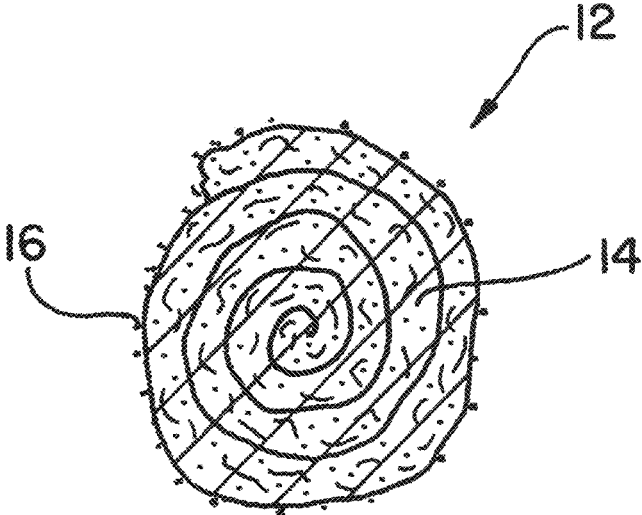

FIG. 2

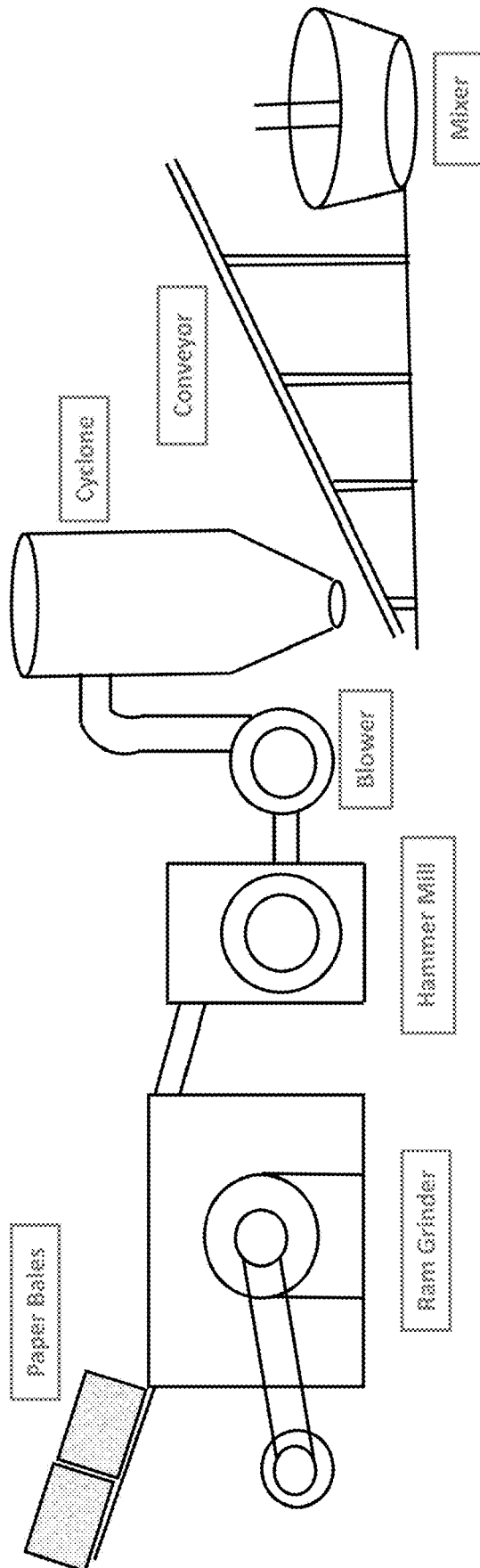

FIG. 3

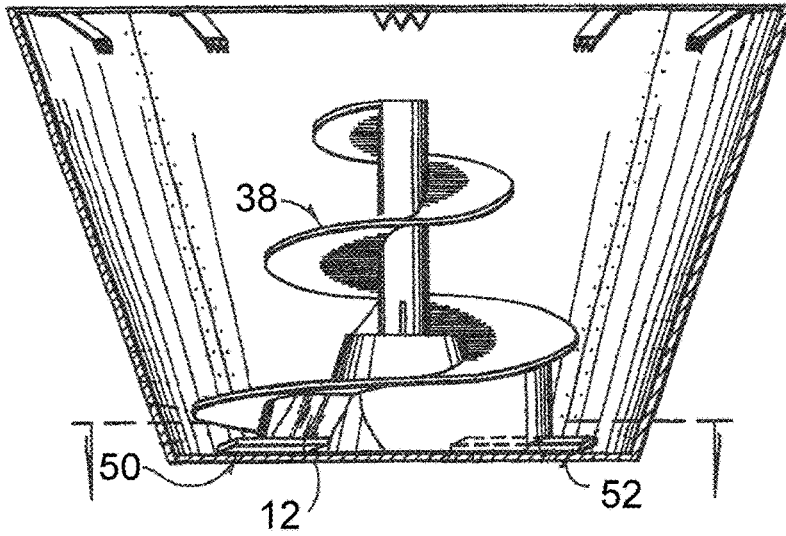

FIG. 4
(Prior Art)

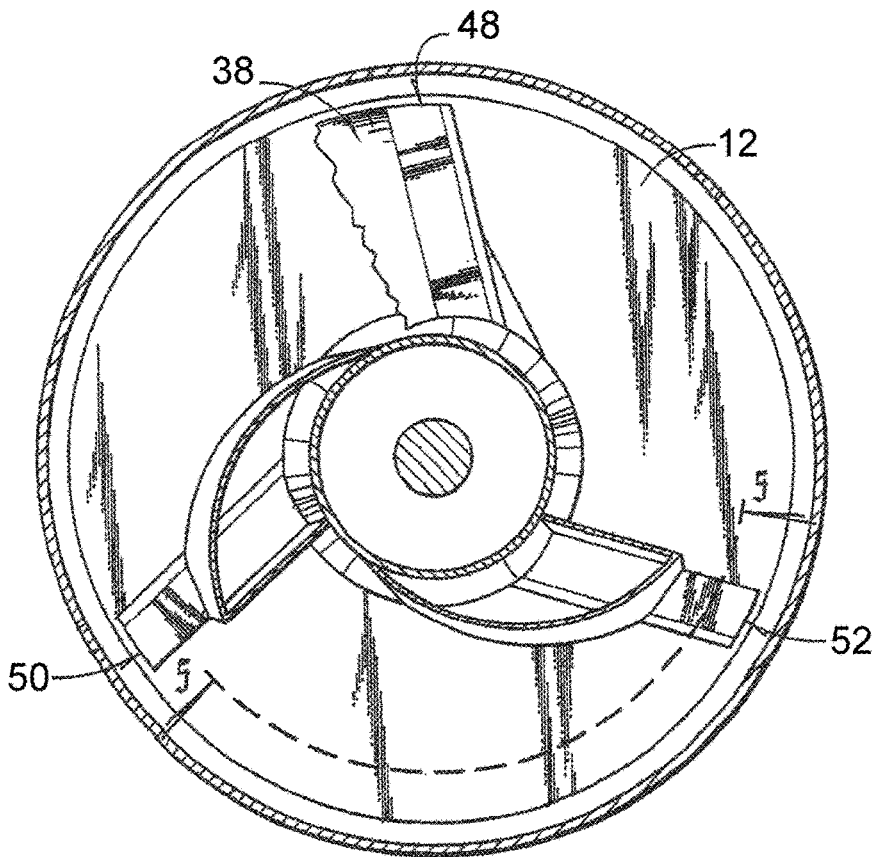

FIG. 5
(Prior Art)

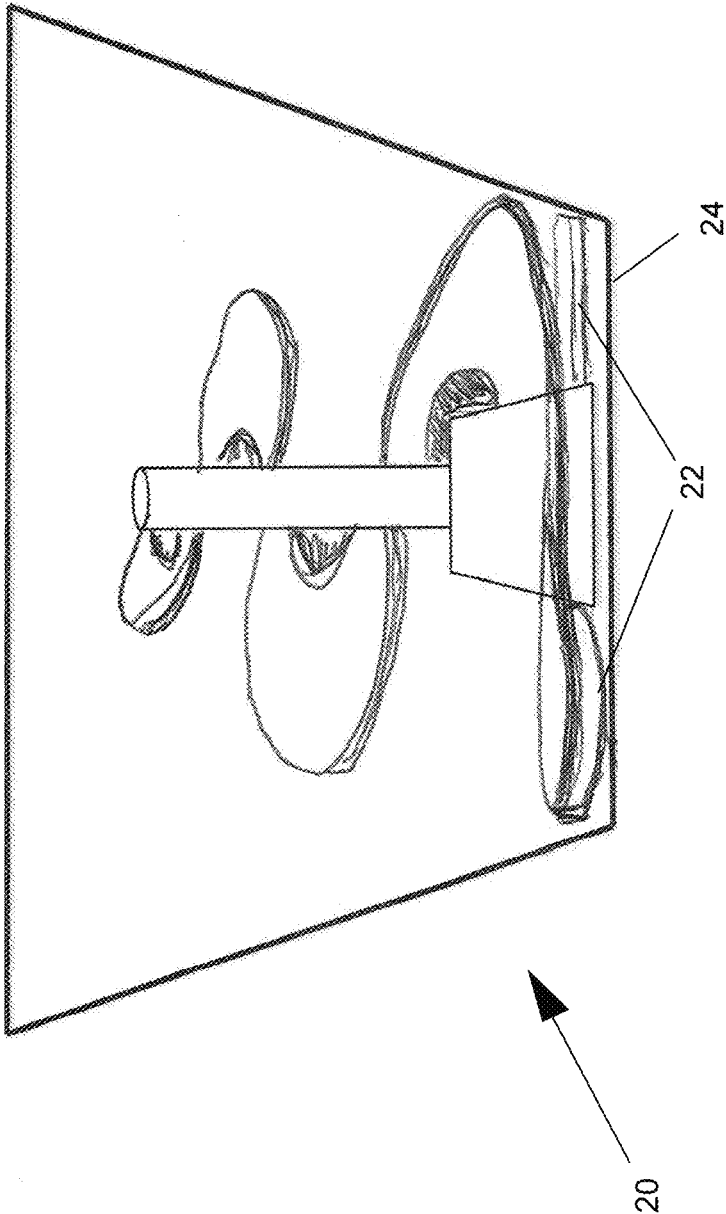

FIG. 6

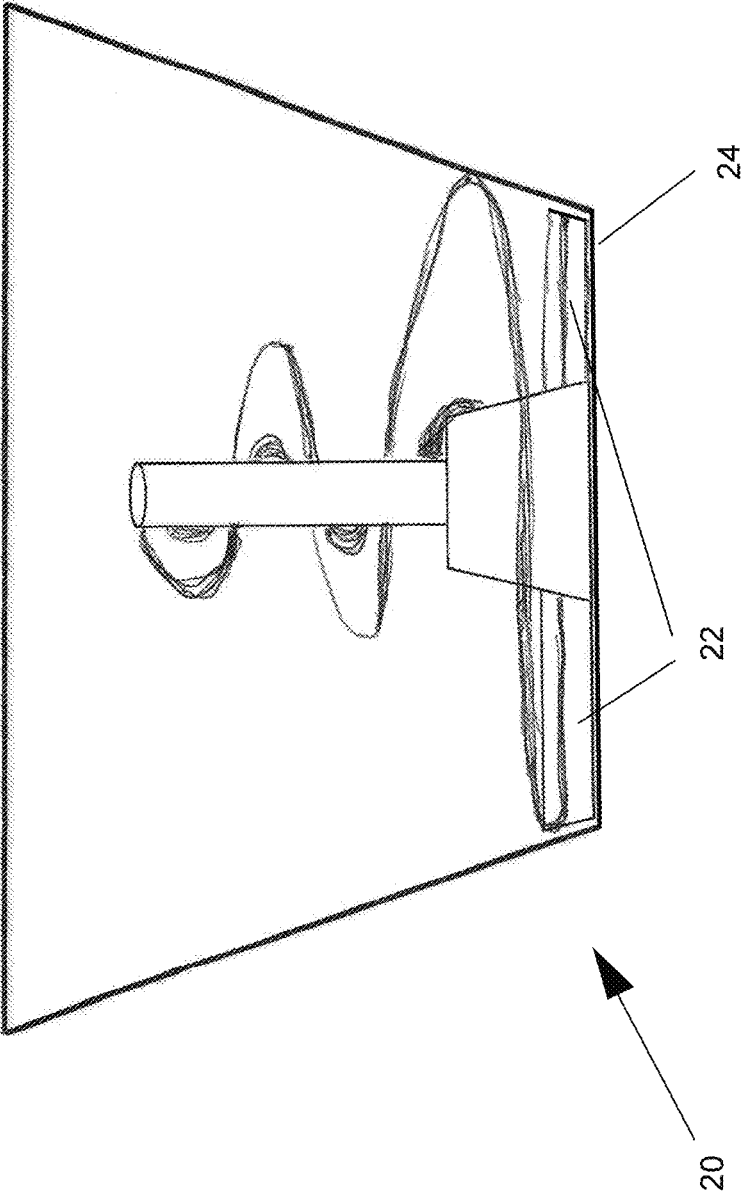

FIG. 7

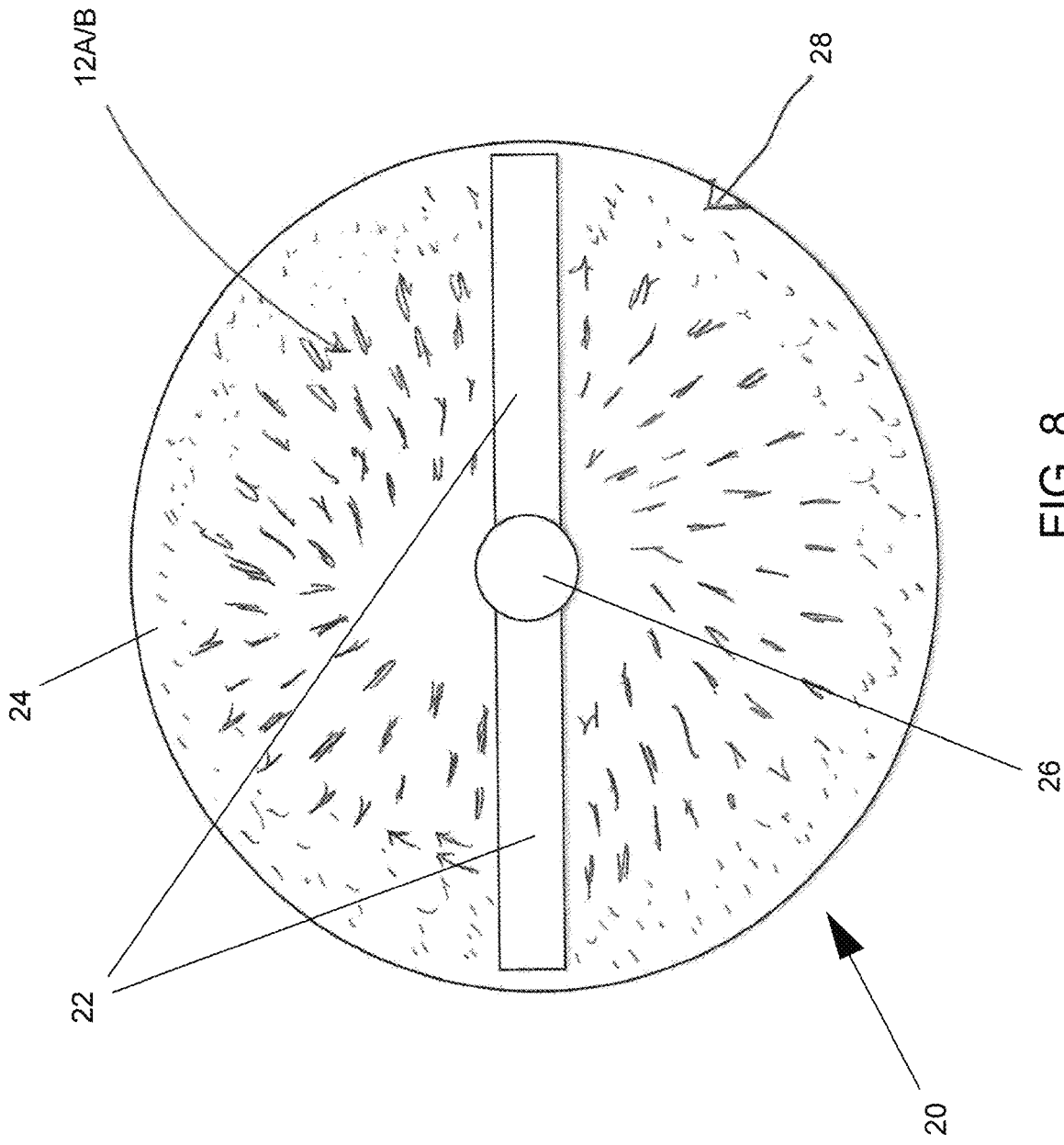

FIG. 8



FIG. 10



FIG. 12

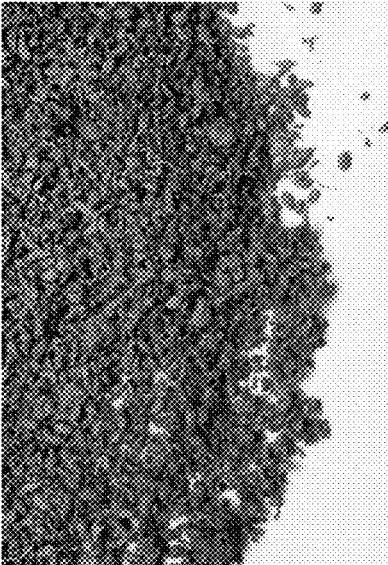

FIG. 9



FIG. 11



FIG. 13



FIG. 14

BULK ANIMAL BEDDING

This is a continuation-in-part patent application of pending U.S. patent application Ser. No. 17/521,022 filed Nov. 8, 2021, which claims the benefit of U.S. U.S. patent application Ser. No. 14/856,663 filed Sep. 17, 2015, which claims the benefit of U.S. Provisional Application No. 62/060,911 filed Oct. 7, 2014. The contents of these prior patent documents are incorporated herein by reference.

BACKGROUND OF THE INVENTION

The present invention generally relates to materials of types used to improve the aeration and/or moisture retention in soils. More particularly, this invention relates to materials formed from paper-type materials and capable of exhibiting properties that enable their use as substitutes for peat moss.

The use of peat moss, and particularly sphagnum peat moss, for the purpose of conditioning soils is widely practiced by hobbyists and professional gardeners and growers alike. Peat moss is widely used to pack and pot plants, with sphagnum peat moss typically being most preferred by gardeners and growers. When mixed with soil, sphagnum peat moss serves to aerate the soil while simultaneously enhancing moisture retention, both of which are highly desirable soil qualities for starting and growing plants.

Sphagnum peat moss (or simply, sphagnum peat) can be found in bogs predominated by sphagnum moss, a genus of moss. Sphagnum moss that is found in the upper layers of more recent growth has not yet had the chance to decay or breakdown, and as a result has desirable characteristics of being long fibered with irregular, clustered branchlets with irregularly shaped or spherical voids, which contribute to the ability of sphagnum peat moss to retain moisture when mixed with soil. However, the availability of sphagnum peat moss in the U.S. can be relatively poor because of being a limited resource, and sphagnum peat moss accounts for only a fraction of all peat moss produced in the U.S. The majority of sphagnum peat moss is imported from Canada and Northeastern Europe.

In view of increasing environmental concerns, substitutes for various types of natural soil conditioners have been sought by the agricultural industry, with many approaches utilizing recycled materials to simultaneously provide a use for solid waste materials. For example, U.S. Pat. No. 3,876,411 to Fowler discloses a mulch which is composed of waste organic materials and latex materials that are byproducts of the manufacturing of polymers. Cellulosic materials such as waste paper have generally been identified as suitable materials for mulches, as recognized by U.S. Pat. No. 4,067,140 to Thomas, U.S. Pat. No. 4,123,489 to Kelley, U.S. Pat. No. 4,297,810 to Hansford, and U.S. Pat. Nos. 4,357,780 and 4,414,776 to Ball. Notably, the above patent documents are generally directed to mulches which, by definition, are intended to be spread on the surface of the soil around plants in order to prevent the evaporation of water from the soil and prevent the plant's roots from freezing. Consequently, these mulches are generally described as having a fibrous character which can be spread or sprayed as an aqueous slurry, or as forming a fibrous web that can be placed in sheet form on the ground. To remain in place the mulch material must have adhesive properties or a sufficient bulk density to avoid erosion by wind or water. Therefore, these compositions are not directed toward finding a substitute for peat moss, nor are these compositions generally suitable for use as such, primarily due to their large conglomerate nature which inhibits their ability to mix well into the soil.

The horticulture industry has utilized grades in describing peat moss used for various applications. Screened shredded fibrous peat moss such as sphagnum is a premium variety for soil conditioning. It generally requires milling and screening for use in other applications, for example, propagation, seed starting and/or rooting applications, which have specific requirements for moisture retention. Manufacturers of propagation media, including propagation plugs, utilize milled short fibered peat that will more easily flow through various mechanical apparatus in the production process. Larger fiber materials, including peat mosses, can result in difficult handling and inadequate filling of containers. For commercial and private growers who grow seedlings, a small fiber material more easily fits into small seed or plug trays, whereas larger fiber material, such as sphagnum peat mosses, can cause bridging of the material above seedling tray cavities. With these considerations, the current industry standards for seed starting applications include vermiculite, milled peat moss, and processed sphagnum peat moss, most often found in lower, more decomposed strata of sphagnum peat bogs.

In view of the above, it would be advantageous to provide soil conditioning substitutes for sphagnum peat moss that would exhibit the desired characteristics of this type of moss, such as high moisture retention and the ability to readily blend into the soil to provide aeration. It would also be advantageous to provide propagation media substitutes for milled peat moss that would exhibit desirable characteristics, such as moisture retention and the ability to be readily manufactured and used.

Sphagnum peat has been used on occasion as animal bedding but due to the dust, difficulty in handling, limited supply, and the difficulty in saturating when dry sphagnum has been a less desirable animal bedding.

SUMMARY OF INVENTION

A bulk animal bedding material is presented comprising shredded and fiberized natural lignocellulosic material vigorously blended with a solvent and small grain particles (SGPs) to form twisted, curled, clumped, and rolled fibers with the SGPs integrated within and/or encasing said fibers. The shredded and fiberized natural lignocellulosic material range in diameter from 0.1 millimeter to 5 millimeters and in length from 0.1 to 50 millimeters. The solvent comprises water. The bulk animal bedding material may include blended glues and tackifiers.

The bulk animal bedding ranges in from 0.2 cm to 1.5 cm in diameter across a broadest dimension. The bulk animal bedding may have a dry bulk density of 50 to 250 grams per liter.

The SGPs may be about $\frac{1}{16}$ to about 1 mm in size. The SGPs comprise one or more of hoof and horn materials, ground shells, ground pits, ground seeds, coffee grounds, chaff, hulls, brewery waste, granulated products of fermenting and fuel production, ground shells, ground or processed forestry products, calcined clay, sand, fused earth products, pumice, volcanic ash, perlite, vermiculite, gypsum, lime, fertilizer, coal fines, rock dust, ground glass, concrete, asphalt, metal, food service containers, solidified fibers, plastics, and processed plastics.

Those skilled in the art will realize that this invention is capable of embodiments that are different from those shown and that details of the devices and methods can be changed in various manners without departing from the scope of this invention. Accordingly, the drawings and descriptions are to

be regarded as including such equivalent embodiments as do not depart from the spirit and scope of this invention.

BRIEF DESCRIPTION OF THE DRAWINGS

For a more complete understanding and appreciation of this invention, and its many advantages, reference will be made to the following detailed description taken in conjunction with the accompanying drawings.

FIG. 1 represents the general appearance of individual fibers and particles of a bulk material in accordance with certain embodiments of this invention;

FIG. 2 is a cross-sectional view of an individual fiber or particle represented in FIG. 1;

FIG. 3 represents a processing system of a type suitable for producing the fibers and particles of FIGS. 1 and 2;

FIGS. 4 and 5 are side and top views of a prior art mixer disclosed in U.S. Pat. No. 5,647,665;

FIG. 6 shows a mixer similar to that of FIGS. 4 and 5, but with a modified blade at its lowermost extent;

FIG. 7 shows a mixer similar to that of FIG. 6, but with further modified blades at its lowermost extent;

FIG. 8 represents a top view of the mixer of FIG. 6 and showing materials produced by the mixer;

FIGS. 9 and 11 are photographs showing twisted, curled, clumped and rolled particles of a type represented in FIG. 1;

FIGS. 10 and 12 are photographs showing twisted, curled, clumped and rolled fibers of a type represented in FIG. 1;

FIG. 13 is a photograph comparing individual fibers and particles of the types represented in FIG. 1 and shown in FIGS. 9 through 12; and

FIG. 14 is a comparative photograph of sphagnum peat moss.

DETAILED DESCRIPTION OF THE INVENTION

According to the present invention, bulk materials are provided that are suitable for use in the agriculture horticulture industry. The bulk materials include soil conditioning media, absorbent materials, chemical carriers, and filtering materials that are suitable as direct substitutes for peat moss and, in preferred embodiments, sphagnum peat moss, and media that are suitable for propagation, seed starting, and/or rooting applications. The bulk materials can be primarily produced from paper products, nonlimiting examples of which are waste paper products including newspapers and cardboard, which are processed to form small twisted, curled, clumped and rolled fibers or particles, as defined below. The bulk materials can be produced to sufficiently exhibit the textural and physical properties of peat moss, in some cases sphagnum peat moss, such that they can be readily mixed into soil in order to promote moisture retention and enhance aeration in the soil, or used as media for propagation, seed starting and/or rooting applications. Furthermore, the bulk materials preferably contain SGPs of one or more granular materials as a constituent, for example, bone meal alone or in combination with one or more other granular materials. As used herein, an SGP is a small grained particle that is smaller than the fibrous products used to produce the bulk materials and is abrasive to the fibrous paper products. The fibrous lignocellulosic products and SGPs can be processed such that the SGPs aid in the formation of the twisted, curled, clumped, and rolled fibers or particles (for convenience, hereinafter referred to simply as rolled fibers and rolled particles, respectively).

For purposes of this invention, SGPs can be composed of any solid material that remains solid or will fragment or dissolve during processing or over time in the use of the bulk materials. The solid material and SGPs formed thereof can be ground, sized, formulated, and/or synthesized naturals or manufactured materials. As an example, SGPs may be solid materials derived from processed agricultural products, by-products, or waste from processing such as (but not limited to) those of the type derived from food, fiber, fuel, fisheries, forestry and other production and processing systems. These solid materials include but are not limited to many agricultural products and by-products; as nonlimiting examples, bone meal, hoof and horn materials, ground shells, ground pits or seeds, coffee grounds, chaff, hulls, brewery waste and granulated products of fermenting and fuel production, ground shells, ground or processed forestry products, and combinations thereof. SGPs may also be solid materials derived from mining and earthen particles that have been processed to formulate granules. Minerals and ores of all types can range in size from sand to silt and clay and may be reconstituted to granules that have a desired particle size as discussed below. These solid materials include but are not limited to calcined clay, fused earth products, pumice, volcanic ash, perlite, vermiculite, gypsum, lime, fertilizers, coal fines, rock dust, and any combinations thereof. SGPs may also be solid materials derived from recycled products that have been processed to formulate granules of the desired particle size. Nonlimiting examples of waste materials that can be used include materials from manufacturing and processing, construction, excavation, food preparation and food delivery services, and any other waste materials that can be milled processed or granulated to the desired particle sizes. These solid materials include but are not limited to ground glass, concrete, asphalt, and metal, food service containers, solidified fibers, plastics, and processed plastics, and various other waste and recycled products. SGPs may also be any solid material that will remain solid for a part of the processing and/or into the application of the finished material. In view of the foregoing, the source and formulation of the SGP can vary depending on the properties and desired application of the bulk material. In some instances, the SGP can be selected to alter the acidity, alkalinity, and nutrient properties of the bulk material and therefore the ability of the material to promote plant growth and maintain a desired range of pH. As a nonlimiting but in some instances preferred SGP, bone meal (calcium phosphate) advantageously contributes fertilizer-grade phosphorus and nutrient-grade calcium to the bulk material.

The bulk materials of this invention are able to utilize waste paper and other agricultural and forest materials that typically comprise lignin and cellulose, such as newsprint, which has been shredded to form small shredded fragments, more preferably a fluff material referred to herein as a cellulose fluff material. Vigorous blending with the SGPs and a controlled amount of liquid transforms the fluff material into the above-noted rolled fibers or rolled particles. The rolled fibers or rolled particles have a sufficiently small size in order to exhibit desired physical characteristics, preferably simulating either sphagnum peat moss or milled peat moss, depending on the intended application, for example, as a soil conditioner, absorbent material, chemical carrier, filtering material, or propagation media. The SGPs can become distributed within the rolled fibers or rolled particles and may optionally form a layer that individually and substantially encases each of the rolled fibers or rolled particles. For example, if present as a cohesive layer, agricultural grade bone meal can assist in the retention of

moisture in each of the rolled fibers or rolled particles, and may also contribute fertilizer, for example, fertilizer grade phosphorus. The bulk materials (for example, soil conditioner, absorbent material, chemical carrier, filtering material or propagation media are thereby composed of a mass of individual rolled fibers or rolled particles, and are preferably characterized by a texture and a moisture-retention capability which is comparable to that of either sphagnum peat moss or peat moss, including milled peat moss.

The physical characteristics of the materials which enable the above are generally represented in FIGS. 1 and 2, which illustrate a bulk material 10 as individual materials (pieces or bodies) 12 having the aforementioned "rolled" form, more particularly, a twisted, curled, and/or clumped shape and a rolled structure. Some of the materials 12 have a more elongate shape, referred to herein as the rolled fibers 12A, whereas the remainder are smaller and referred to herein as the rolled particles 12B, in some instances having a more spherical shape than the rolled fibers 12A. The rolled fibers 12A and rolled particles 12B can be selectively produced by adjusting the processing method by which they are created, as will be described below. The rolled particles 12B have a smaller, tighter, denser fibrous structure that is particularly desirable for use in propagation, seed starting and/or rooting applications in small seed starting cells or any other application as a substitute for milled peat moss or similar material. In contrast, the rolled fibers 12A have a looser, loftier fibrous structure that is particularly desirable for use as a soil conditioner, absorbent material, chemical carrier, or filtering material, filling large containers for bedding plants and hanging baskets, or any other application as a substitute for sphagnum peat moss or similar material. Notably, the smaller size of the rolled particles 12B enables a bulk material 10 of the rolled particles 12B to more easily flow through various mechanical equipment that might be used in a production process to produce propagation plugs, or if used to fill small seedling tray cavities.

Generally, it is preferable that the largest dimensions (lengths) of the rolled fibers 12A and rolled particles 12B do not exceed about eight millimeters, for example, about one millimeter up to a maximum dimension of about six to eight millimeters, in order to ensure that they can be readily mixed with soil. In practice, for example, at least some and preferably most of the rolled fibers 12A are greater than two millimeters and up to about five millimeters in length and, as evident from FIG. 1, the rolled particles 12B tend to be smaller than the rolled fibers 12A, for example, at least some if not most are less than 2.5 millimeters in length. As such, the maximum dimensions for the rolled fibers 12A and rolled particles 12B are believed to result in both forms of the material 10 being physically distinguishable from traditional mulch materials. The rolled fibers 12A and rolled particles 12B can preferably be readily mixed with shovels or trowels typically used by both commercial growers and home gardeners. However, it is foreseeable that larger sized rolled fibers 12A and rolled particles 12B may be suitable under some circumstances.

As shown in FIG. 2, each individual rolled fiber 12A and particle 12B is generally composed of a core 14 formed almost entirely of cellulose fiber. SGPs 16 of a granular material, for example, bone meal, are represented as being dispersed throughout the fiber/particle material 12. The SGPs 16 may optionally form a cohesive layer that substantially encases the rolled fiber 12A or rolled particle 12B. The manner in which the rolled fibers 12A and rolled particles 12B are produced preferably yields the generally rolled or coiled structure shown for the core 14, while the SGPs 16

may be absorbed somewhat into the core 14, particularly between overlapping portions of the core 14 (shown as rolled and coiled in FIG. 2). The source of the cellulose fiber can vary considerably. Cellulose insulation has been used, though waste paper, particularly newsprint, is preferred due to availability, relatively low cost, and ability to be readily processed to form the desired rolled fibers 12A and rolled particles 12B shown in FIG. 1. For example, the processing of newsprint can be controlled to readily produce the relatively loose rolled fibers 12A or the more tightly wound rolled particles 12B represented in FIG. 1. The rolled structure of the core 14 enhances the ability of the rolled fibers 12A and rolled particles 12B to retain moisture, which is a desirable characteristic of peat moss and any composition intended as a replacement for peat moss.

Processes that are believed to be preferred to produce the materials 10 are highly advantageous from the standpoint of material and processing costs. As represented in FIG. 3, the processes primarily include a shredding operation in which paper such as newsprint is reduced to cellulose particles or fluff material. In FIG. 3, such a shredding operation may start with bales of paper that are processed by a ram grinder and then a hammer mill, resulting in the cellulose fluff material that is blown into a cyclone/dust collector to remove excessively fine particles. The fluff material is then gently deposited onto a conveyor and fed into a finish mixer. Suitable ram grinders, hammer mills, cyclone/dust collectors, and conveyors are well known and will not be discussed in any further details.

Within the mixer, the cellulose fluff material is combined with water, the SGPs (for example, bone meal), and optionally any desired colorant(s) and/or additional additives. Within the mixer, the fluff material is moistened and, in a process that is believed to involve the action of the SGPs, substantially transformed into the rolled fibers 12A or rolled particles 12B. Sufficient moisture is present in the mixer such that the SGPs 16 form a slurry that promotes grinding of the fluff material and may optionally form the cohesive layer that substantially covers the individual rolled fibers 12A or rolled particles 12B. In particular, the SGPs 16 are believed to have a significant role as an abrasive agent in the mixing process. The SGPs 16 appear to play a significant role in breaking down the cellulose fluff material as the mixture of fluff material and SGPs 16 is ground/milled beneath a lowermost blade of the mixer. Mixing preferably continues for a duration sufficient to permit separation of the rolled fibers 12A or rolled particles 12B, such that a mass of the rolled fibers 12A or rolled particles 12B is characterized by a desirable texture and moisture-retention capability. If present, the cohesive layer of bone meal on each rolled fiber 12A or rolled particle 12B assists in the retention of moisture within each rolled fiber 12A or rolled particle 12B.

An example of a known type of mixer is represented in FIGS. 4 and 5. The mixer, which is disclosed in U.S. Pat. No. 5,647,665, is intended as a feed mixer, for example, to produce silage for cattle. FIGS. 4 and 5 show the mixer as having a corkscrew-like auger 38 and lowermost grader blades 48, 50 and 52, the latter of which are spaced apart from the floor 12 of the mixer. FIGS. 6 and 7 represent mixers 20 that are similar to that of FIGS. 4 and 5, but modified such that at least a portion of at least one of their lowermost blades (sweep bars or swing arms) 22 is in closer proximity to the floor 24 of the mixer 20 than that represented in FIGS. 4 and 5. The mixer 20 in FIG. 6 has at least one bent lowermost blade 22 having a portion in closer proximity to the floor 24 than the remainder of the blade 22, whereas the entirety of each blade 22 of the mixer 20 in FIG.

7 has roughly the same tight clearance with the floor 24 as the bent portion of the blade 22 of FIG. 6. The tight clearance is believed to be a key factor in the manipulation of the cellulose fluff material into the desired rolled fibers 12A or rolled particles 12B, as longer chains of fibers/particles appeared beneath the bend with each rotation of a mixer configured similar to the mixer 20 of FIG. 6. In that particular embodiment of the mixer 20, at least one of its lowermost blades 22 had a downward bend spaced apart from the radial outermost end of the blade 22, roughly starting about 5 to 6 inches (about 7.5 to 15 cm) from the radial outermost end of the blade 22 and continuing about 12 to 14 inches (about 30 to 35 cm) toward the center of the shaft 26 on which the auger and blades 22 were mounted. In investigations leading to the present invention, the mixer configured as shown in FIG. 6 appeared to exclusively produce rolled fibers 12A or rolled particles 12B beneath the bend in its lowermost blade 22, as represented in FIG. 8. In contrast, beneath portions of the blades 22 spaced farther from the floor 24 of the mixer 20, only small cellulose particles 28 were observed but no formation of rolled fibers 12A or rolled particles 12B. The cellulose particles 28 visually appeared as if they have not yet been affected or manipulated by the blades 22. Tighter clearances as described above were also tested in a closed batch ribbon mixer and appeared to duplicate the desired characteristics of rolled fibers 12A or rolled particles 12B that were produced with the mixer 20 of FIG. 6.

The twisted, clumped and rolled structures of the rolled fibers 12A and rolled particles 12B are advantageous when mixing the material 10 into soil, in that the rolled fibers 12A or rolled particles 12B will more readily mix into the soil than would shredded or fibrous particles, yet the rolled fibers 12A and rolled particles 12B also retain some of the advantages of a fibrous structure as a result of being formed from fibrous fluff material. It is believed that the internal fibrous nature of the rolled fibers 12A and rolled particles 12B, as opposed to their external clumped structure, serves to extend the longevity of the cellulosic food for microbes within the soil.

As is known in the art, bone meal is a product made by grinding animal bones, with commercially available bone meal generally containing tricalcium phosphate and phosphoric acid, with smaller amounts of ammonia also being present. Bone meal is believed to be preferred as the SGPs 16 for this invention and is preferably of the type designated as fertilizer grade, which is raw bone meal that has not been previously steamed, though steamed bone meal, generally designated as feed grade bone meal, could also be used. In some embodiments, the SGPs 16 of bone meal may constitute a weight percent of as low as about 0.2% to as high as about 35% of each of the rolled fibers 12A or rolled particles 12B, based on the mixing rate of bone meal with the fluff material, though it is entirely foreseeable that greater or lesser amounts of bone meal could be utilized and yet obtain rolled fibers 12A and rolled particles 12B suitable for use under some conditions. Furthermore, part or all of the bone meal could be replaced with another granular material that meets the definition herein of an SGP, a notable but non-limiting example of which is sand (reported on the Wentworth Scale to have a particle size of $\frac{1}{16}$ to 1 mm). The SGP type and the final moisture content of the bulk material may vary considerably to meet specific applications. The resulting bulk material 10 may have a density as low as about 50 grams per liter to as high as about 1500 grams per liter. A preferred range for use as a substitute for common peat moss or milled peat applications is believed to be from about 70

to about 400 grams per liter, which advantageously is comparable to that of peat moss as used for agricultural purposes.

As a result of the above structure, the bulk materials 10 of this invention can exhibit textural and moisture absorption and retention characteristics very similar to that of sphagnum peat moss or milled peat moss, in that the rolled fibers 12A and rolled particles 12B are suitable substitutes for, respectively, sphagnum peat moss as a soil conditioning agent or milled peat moss as a propagation media. The materials 10 may also provide benefits beyond those of sphagnum and milled peat moss, for example, as a result of containing bone meal as the SGP, which contributes phosphorus to the soil for stimulating plant growth. Furthermore, if part or all of the bone meal is replaced with another SGP and/or an additional additive is combined with the cellulose fluff material and SGP, the SGP and/or additive can be selected to alter the nutrient properties and/or non-nutrient properties (physical, chemical, and biological) of the materials 10 (as examples, plant protecting and growth enhancing materials such as bio-stimulants, growth regulators, natural and chemical pesticides, fungal and bacterial inoculants, etc.), and thereby enhance the ability of the material 10 to promote plant growth.

Processes by which either the rolled fibers 12A or rolled particles 12B can be selectively produced generally relate to the amount of liquid used in the process. Typically the liquid will be water that is added to the mixer 20 in an amount sufficient to moisten the cellulose fluff material and SGPs 16, though it is foreseeable that other liquids could be used as long as the liquid is biologically compatible with the intended purpose of the bulk material 10. As previously noted, the SGPs 16 preferably have an abrasive effect to promote the breaking down of the cellulose fluff material as the mix of cellulose fluff material and SGPs 16 is ground and/or milled beneath the lowermost blade(s) 22 of the mixer 20. Before, during or after the addition of SGPs 16, additional liquid can be introduced into the mixer 20, as well as any coloring agent or other desired liquid or solid additive. However, a relatively greater amount of moisture is required to produce the rolled particles 12B, which results in the creation of a slurry with the cellulose fluff material that promotes the formation of the desired rolled particles 12B. After a period of continuous mixing, the cellulose fluff material is transformed into a substantially homogenous mass of rolled fibers 12A or rolled particles 12B.

Once the physical shape of the rolled fibers 12A or rolled particles 12B is acquired, mixing may continue for a duration sufficient to dry the rolled fibers 12A or rolled particles 12B, for example, sufficient to permit the rolled fibers 12A or rolled particles 12B to be freely separated and subsequently handled for packaging. Bulk materials 10 formed of either the rolled fibers 12A or rolled particles 12B as described above have been evaluated for water absorption, water retention and aeration capacity, with excellent results. Commercial trials have also shown that these bulk materials 10 are able to achieve better propagation success rates than vermiculite and milled peat moss.

Grinding/milling processes applied as described above to the manufacturing of the bulk material 10 appears to alter the fiber structure of the feed material (e.g., recycled newspaper) to create materials 12 having a desirable combination of properties, including high porosity and low bulk density. Increased porosity promotes oxygen exchange to the roots of plants and enhances availability of water. Low bulk density provides ease of handling and reduces shipping costs. FIGS. 9 and 11 are photographs of rolled particles 12B produced in

accordance with the above description, FIGS. 10 and 12 are photographs of rolled fibers 12A produced in accordance with the above description, and FIG. 13 is a photograph showing a side by side comparison of the two. Significant features of the rolled fibers 12A and rolled particles 12B that can be seen in these images include a clumped, curled, twisted, and rolled, rearranged cellulose material having a consistent, milled fiber size or particle size that is favorable to achieving a uniform moisture-holding, oxygen-holding and fertilizer-holding capacity, promoting the use of rolled particles 12B and particularly the rolled fibers 12A as an absorbent material or chemical carrier. The clumped, curled, and twisted shape of the cellulose material can also promote the use of a mass of the rolled fibers 12A and/or rolled particles 12B as a filtering material. Unseen in FIGS. 9 through 13, but determined by other methods, was high porosity characterized by a consistent pore space that is critical to a more uniform moisture-holding, oxygen-holding, fertilizer-holding, or filtering capacity, and a moisture-holding capacity that exceeds by up to about 170% by weight that of long fiber sphagnum peat moss without a surfactant or wetting agent. Significantly, the increased moisture retention and oxygen exchange likely increase the reliability of seed germination, for example, up to about 97% in experimental trials.

In contrast, significant features of peat moss that can be seen in FIG. 14 include a lack of consistent particle size, and a flattened fiber structure that has been expanded as the result of the application of a surfactant. As known in the art, after drying peat moss must have a surfactant or wetting agent applied to promote moisture absorption and retention. In contrast, the rolled fibers 12A and rolled particles 12B have been shown to have an affinity for water, and readily absorb water when very dry.

From the above, it can be seen that a significant advantage of this invention is that the bulk materials 10 can be selectively produced from similar materials yet have different characteristics that render them particularly suitable as substitutes for either sphagnum peat moss or milled peat moss in an array of applications.

Another embodiment of the bulk material presented herein may be used as animal bedding. In this embodiment, the bulk material is made of feed material that is primarily shredded and fiberized natural lignocellulosic material. The lignocellulosic materials are primarily derived from recycled cardboard and newspaper or other agricultural, forestry, or recovered waste fibrous materials. The feed material can include fibers such as grasses, hemp, straw, corn stover, hay, willow, pine, poplar, and other lignocellulosic fibrous materials and these fibers can be mixed in various ratios and combinations. The feed materials are shredded and fiberized and then reformulated by applying water and/or another solvent as described earlier to roll, twist, curl, and clump the fibers into agglomerated particles that contain SGPs interspersed within and outside the agglomerated particles. Other additives may also be included.

The size of the shredded and fiberized natural lignocellulosic material can range in diameter from 0.1 millimeter to 5 millimeters and in length from 0.1 to 50 millimeters. These partially or completely separated materials are vigorously blended with the inclusion of the solvent(s), additives, and SGP's in a process to incorporate the SGP's and additives into the structure of the agglomerated particles with the additives and SGP's interspersed within and outside the particles. Glues and tackifiers can be included during the blending process to alter the properties and modify the final

structure of the animal bedding. The additives that can be incorporated to influence the physical, chemistry and biological properties including pH, soluble salts, redox potentials, mineral availability and balances, nutrient supplies, physical structure, inoculants, sterilant, surfactants, pesticides, fungicides, insecticides, etc.

The finished agglomerated particles have an irregular shape with a largest dimension ranging from 0.2 to 1.5 cm in diameter with the most common ranging from 0.3 to 0.7 cm across the broadest dimension. In some embodiments, longer fibers that are or are not intimately incorporated in the agglomerated particles and can be interspersed between and within, or partially within and extending outside, the agglomerated particles to alter the physical properties of the bulk material. These fibers could stand alone in the mix and/or protrude from within the agglomerated particles to as long as from 5 cm outside the agglomerated particles thus adding an ability to cling within the mass of bulk material.

The solvent is typically water but can include any number of liquid solvents that are polar or nonpolar. The SGP's can be soluble or insoluble materials. The soluble SGP materials can fully dissolve or partially dissolve in the presence of the solute, preferably water, and any insoluble materials will remain as spacers to bridge between the fibers thus providing some rigidity and spaces (micropores) for porosity within the agglomerated particles. Larger spaces or voids between the agglomerated particles (macropores) provide large pores in the mass of nested particles allowing for gas exchange and aeration while the fine spaces between the bridged fibers and within the conglomerated fibers provide pores for holding water, nutrients, and additives. These micropores also allow fluids, microbes, inoculum, chemical carrier granules, soluble and insoluble chemicals and an array of fine materials within and outside the agglomerated particles when the animal bedding is in use.

The internal structure of the agglomerated particles and the external structure between the particles provides for a mass substrate that can hold and house physical, chemical, and biological materials to foster better absorption, and microbial activity with retention of animal waste including urine and feces. The micro and macro pores provide for absorption of liquids and solids by the lignocellulose fibers. They also allow for gas exchange for drying and input of air and output of respiration gasses. Thus, allowing drying and aerobic respiration. The fine fibers provide a vast surface area to house microbes necessary for the metabolism of the animal waste. Being composed primarily of natural lignocellulosic fibers they provide the carbon source that is readily present in immediate contact with the microbes and available for the metabolic activity within the substrate microbiome.

In use as an animal bedding, the surfaces of the fibers exposed to the animal waste is much greater with the finer structure of the fibers of the bulk material. The separation of fibers by the incorporation of the SGPs allowing waste gasses, fluids, and particles to be in intimate contact with the lignocellulose fibers. The surfaces provide for increased areas on which microbes can prosper. Additionally, that surface area further enhances drying of liquid wastes absorbed by the animal bedding. It has been found that animal bedding produced from the bulk materials described herein absorb 2.46 times that of wood chips.

The animal bedding disclosed herein maintains a lower pH as animal litter compared to straw which is critical to abating ammonia emissions. The levels of potassium, calcium, magnesium, and sodium cations and the nitrate and phosphate anions were found to be much higher in the

disclosed animal bedding as compared to straw which indicates that these cations and anions are being better absorbed by the disclosed animal bedding.

It was also found that nitrogen metabolism is altered in the disclosed animal bedding used in chicken houses. As a foundation to understanding how the disclosed animal bedding interacted to apparently capture ammonium and reduce run-off and volatilization, it is necessary to understand the chemistry involved. Poultry excreta is composed of digested solids and uric acid. Some nitrogen is complexed in the organic materials, but the majority is in the uric acid. While in the manure, enzymes from bacteria convert the uric acid to urea and then into ammonium which is a positively charged ion that acts as a salt. It is soluble and absorbed into the manure. Bacteria and simple chemical reactions act to remove a hydrogen ion from the ammonium ion to convert it into ammonia which is a very volatile gas. The ammonia gas then becomes airborne and escapes into the atmosphere. Ammonia levels must be kept below 25 ppm in the air within the chicken houses. Above 25 ppm it has been shown to be very damaging to the health and growth of the birds. Ventilation is necessary to remove excess ammonia. Additionally, ammonia is considered a serious environmental hazard and is damaging to the atmosphere. Further, ammonium and nitrate leachate from manure in the chicken yards and from manure and field applications is a serious concern in water pollution. The sequential equation for these chemical reactions is:

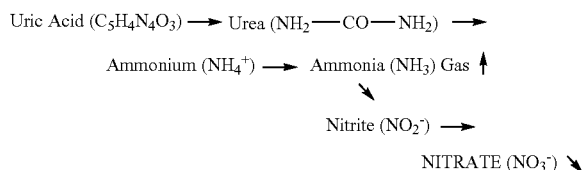

The conversion of uric acid to urea and then to ammonium is dependent on moisture and enzymes produced by bacteria. Ammonium conversion to ammonia is the result of enzymes and chemical reactions. This action requires pH levels above 6.5 and is greatly accelerated at more alkaline conditions near pH 8.0 that is common in most manures. Moisture and warmth accelerate these reactions

Table 1 below shows comparative data from trials at a poultry farm using their standard wood shaving animal bedding compared to the disclosed animal bedding at three weeks and five weeks after the placement of the animal bedding.

TABLE 1

Comparative Data Collected From Poultry Farm Trials				
	Week 3		Week 5	
	Wood Shavings	Disclosed Animal Bedding	Wood Shavings	Disclosed Animal Bedding
Bird Weight (Ounces)	31.95	40.62	82.54	88.1
Ammonia Readings (ppm)	17.78	11.56	10 (fan on)	23.7 (fans Off)
Moisture Readings (%)	23.89	25.56	N/A	N/A
Temperature (° C.)	29.08	30.63	N/A	N/A
Mortality %	1.18	1.15	1.65	1.52
Feet Rating (estimated)*	0.00	0.00	2.3	1.3

TABLE 1-continued

Comparative Data Collected From Poultry Farm Trials				
	Week 3		Week 5	
	Wood Shavings	Disclosed Animal Bedding	Wood Shavings	Disclosed Animal Bedding
Bird Appearance	Clean	Very Clean	Some Birds Dirty	Clean
House Conditions	Fans Off	Fans Off	Fans On	Fans Off

*Range 0-3 with 0 perfectly clean to 3.0 bad and not marketable.

It was found that the poultry farm experienced higher survivability and cleaner birds with the disclosed animal bedding as compared to wood shavings.

Table 2 shows an analysis of litter in a turkey farm comparing the use of straw against a mixture of 20% straw and 80% the disclosed animal bedding.

TABLE 2

Turkey Litter Analysis - August 2021			
	Litter Type		Absorption % Increase
	Straw	80% Disclosed Animal Bedding + 20% Straw	
pH	7.41	6.67	-10
EC (total soluble salts)	0.58	3.25	460
% Total Nitrogen	0.36	0.45	25
ppm Nitrate	1.47	52.93	3501
ppm Ammonium	9.62	4.95	-49
ppm Urea	139.03	122.42	-12
ppm Phosphorus	11.59	49.57	328
ppm Potassium	170.99	404.41	137
ppm Calcium	8.39	137.25	1536
ppm Magnesium	2.92	43.3	1383
ppm Sodium	5.6	161.94	2792
ppm Copper	0.05	7.18	14260

It was found that bedding comprising primarily the disclosed animal bedding has significantly superior performance in terms of absorption of minerals and animal waste materials. It was also found that a rapid temperature rise was experienced in the disclosed animal bedding while in storage and composting which supports strong and aggressive microbial growth. The disclosed animal bedding provides the necessary aeration moisture and carbon to foster more aggressive microbial development.

It was also found that the disclosed animal bedding maintains an attractive gray to gray-brown color and natural appearance as opposed to straw or wood chips over the life cycle of use. It was also found that there was no apparent odor from the disclosed animal bedding material compared to traditional bedding systems. The use in the poultry houses greatly reduced the odor in the building as a result of reduced ammonia emissions.

This disclosed animal bedding was also found to have no dust compared to other traditional bedding systems. The disclosed animal bedding material was found to be easier to handle and disperse and easier to insert a shovel or fork compared to wood shavings but about the same as straw.

The testing conducted shows that the disclosed animal bedding exhibits greatly reduced ammonia emissions in the poultry barn and also from the stored or composted manure. Since the soluble media extracts show lower levels of ammonium it is expected that run off will be reduced. Therefore, less surface and ground water pollution can be expected from the disclosed animal bedding compared to traditional bedding systems.

Mortality in young animals is a common problem in poultry and other animals. Poultry are very susceptible to early deaths primarily due to ammonia gases emitted from manure. Good manure management helps reduce the ammonia emissions and thus reduces death. Using the disclosed animal bedding, growers have observed a 2% to 6% reduction in losses. An improved environment by improved litter management increases appetite of animals (especially when young) and also reduces stress on the metabolism (from the absence of noxious gasses) thus promoting improved rates of weight gain. Table 3 shows performance comparisons between the disclosed animal bedding and wood shavings. At the trial farm, a 3.9% increase in daily weight gain was measured. A 2.5% improved efficiency in the growth and weight gain in poultry was also realized in using the disclosed animal bedding.

TABLE 3

Growth Performance Comparing Disclosed Animal Bedding with Wood Shaving*					
	Avg. for Season*	Wood Shavings (1)	Wood Shavings (2)	Disclosed Animal Bedding	Disclosed Animal Bedding % of Season Average
Avg. Weight (lbs.)	5.26	5.12	5.64	5.25	99.8
Days to Harvest	40.4	40.8	42.3	38.8	96.0
Age Adjusted Weight	5.26	5.07	5.39	5.47	103.9
Weight Gain/Day	0.130	0.125	0.133	0.135	103.9
Feed Con. Factor	1.64	1.7	1.6	1.6	102.5
Livability	0.9859	1.0066	1.0074	1.0052	102.0
Performance Index	15246	14705	15744	16596	108.9

*data was obtained from the broker report.

*Avg for 30 area brokered flocks on mostly wood shaving bedding from Sep. 21, 2020 to Nov. 24, 2020

Four common bedding materials were obtained from a local pet supply store and used to compare to the disclosed animal bedding for the ability to absorb moisture. Equal volumes of bedding materials and the disclosed animal bedding were filled into 5-inch round plastic pots that held 1 liter of material when filled. Each material was settled by tapping the pot on the tabletop five times and refilling to the top and re-tapping until all materials were equally filled. The weights were measured and the weight of contents less the weight of the containers. The pots filled with the materials were submerged into water with a weighted covering to avoid floating. After about 20 hours of soaking the pots were allowed to completely drain and were again weighed. All materials were measured in triplicate and the numbers presented are averages. Dry bulk densities of the samples were determined by taking 30 milliliters of each material and weighing then drying in an oven at 220 degrees Fahrenheit for 8 hours. Using the data obtained the moisture absorbing abilities of each material was determined on a volume basis and a dry weight basis. That data is presented in Table 4 below. The "Volume Basis" numbers present the volume of moisture (water, urine, etc.) that a given volume of bedding material will absorb. The "Weight Basis" presents the weight of water that will be absorbed by given weight of dry bedding. For example, a pound of dry disclosed animal bedding will absorb 4.478 pounds of water.

TABLE 4

Moisture Absorption by Animal Bedding Materials		
	Volume of Water Absorbed % Volume	Weight Water Holding Capacity % of Dry Weight
Disclosed Animal Bedding	52.0	447.8
Fine Shavings	31.3	191.1
Coarse Shavings	29.1	163.8
Chopped Straw	37.3	357.9
Shredded Wood	28.2	287.1
Peat Moss	31.3	355.5

While the invention has been described in terms of specific embodiments, it is apparent that other forms could be adopted by one skilled in the art, such as by modifying

the shape of the rolled fibers 12A or rolled particles 12B, utilizing different sources of cellulose fluff material, adding adjuncts during blending which do not materially alter the desired physical and/or textural properties of the materials 10 and their rolled fibers 12A and rolled particles 12B, altering or modifying the processing steps described above yet achieving the desired rolled fibers 12A or rolled particles 12B described, or employing the material 10 for purposes other than a substitute for peat moss. Accordingly, it should be understood that the invention is not limited to the specific embodiments illustrated in the Figures. It should also be understood that the phraseology and terminology employed above are for the purpose of disclosing the illustrated embodiments, and do not necessarily serve as limitations to the scope of the invention. Therefore, the scope of the invention is to be limited only by the following claims.

This invention has been described with reference to several preferred embodiments. Many modifications and alterations will occur to others upon reading and understanding the preceding specification. It is intended that the invention be construed as including all such alterations and modifications in so far as they come within the scope of the appended claims or the equivalents of these claims.

The invention claimed is:

1. A bulk animal bedding material comprising: shredded and fiberized natural lignocellulosic material vigorously blended with a solvent and grain particles (SGPs) to form twisted, curled, clumped, and rolled fibers with the SGPs integrated within and/or encasing said fibers.
2. The bulk animal bedding material of claim 1, wherein the bulk animal bedding material has a dry bulk density of 50 to 250 grams per liter.

3. The bulk animal bedding material of claim 1, wherein the bulk animal bedding material contains internal micro pores and a structure providing external macro pores.

4. The bulk animal bedding material of claim 1, wherein said SGPs are a size of about $\frac{1}{16}$ to about 1 mm. 5

5. The bulk animal bedding material of claim 1, wherein said SGPs comprise one or more of hoof and horn materials, ground shells, ground pits, ground seeds, coffee grounds, chaff, hulls, brewery waste, granulated products of fermenting and fuel production, ground shells, ground or processed forestry products, calcined clay, sand, fused earth products, pumice, volcanic ash, perlite, vermiculite, gypsum, lime, fertilizer, coal fines, rock dust, ground glass, concrete, asphalt, metal, food service containers, solidified fibers, plastics, or processed plastics. 10 15

6. The bulk animal bedding material of claim 1, wherein said shredded and fiberized natural lignocellulosic material range in diameter from 0.1 millimeter to 5 millimeters and in length from 0.1 to 50 millimeters.

7. The bulk animal bedding material of claim 1, wherein the bulk animal bedding material includes blended glues and tackifiers. 20

8. The bulk animal bedding material of claim 1, wherein the bulk animal bedding material ranges in from 0.2 cm to 1.5 cm in diameter across a broadest dimension. 25

9. The bulk animal bedding material of claim 1, wherein said solvent comprises water.

* * * * *