

High Tunnel Gantry

Northeast SARE Partnership Grant ONE21-381

This material is based upon work supported by the National Institute of Food and Agriculture, U.S. Department of Agriculture, through the Northeast Sustainable Agriculture Research and Education program under subaward number ONE21-381.

Research Objectives

- Collaboration with Jericho Settlers Farm.
- Design a prototype High Tunnel Gantry System with 2 implements.
- Build the system and evaluate functionality.
- Quantify labor savings of the implements.
- Publish the designs and present the research.



Why Gantry?

- Demonstrated benefit in large greenhouses, specifically in EU
- Multiple use cases / implements on same framework
- Path to automation, farmers can realize benefits before investing in automation.
- Leverages infrastructure readily available on NE farms.

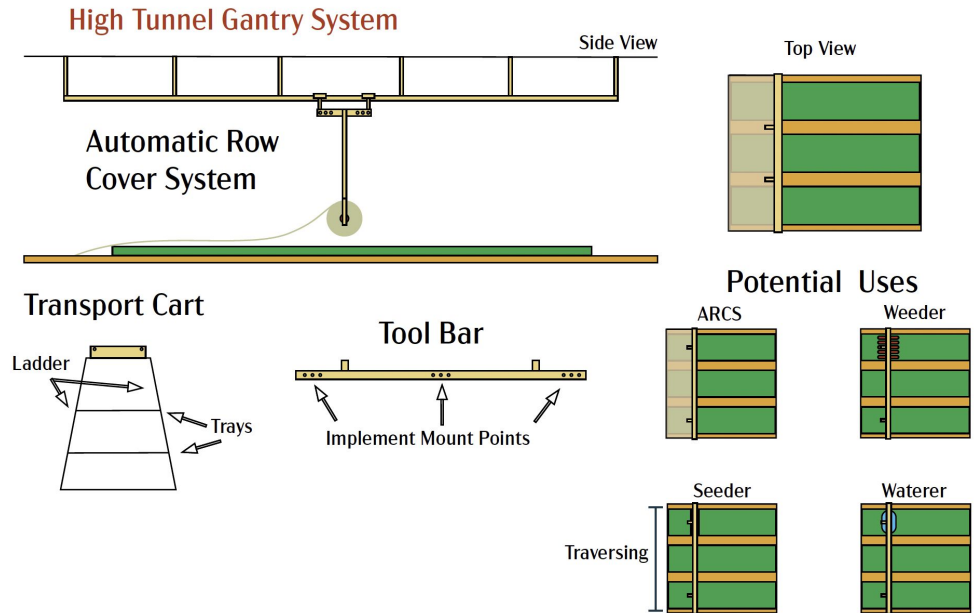

Implement 1: Transport Cart

- Low cost, low maintenance
- Easy to source & implement
- Fast return on investment



Implement 2: Automated Row Cover System

- Novel automation program
- Reduces labor during winter season when staff is light
- Increased management of row cover could maximize sunlight, heat, and ventilation on crops

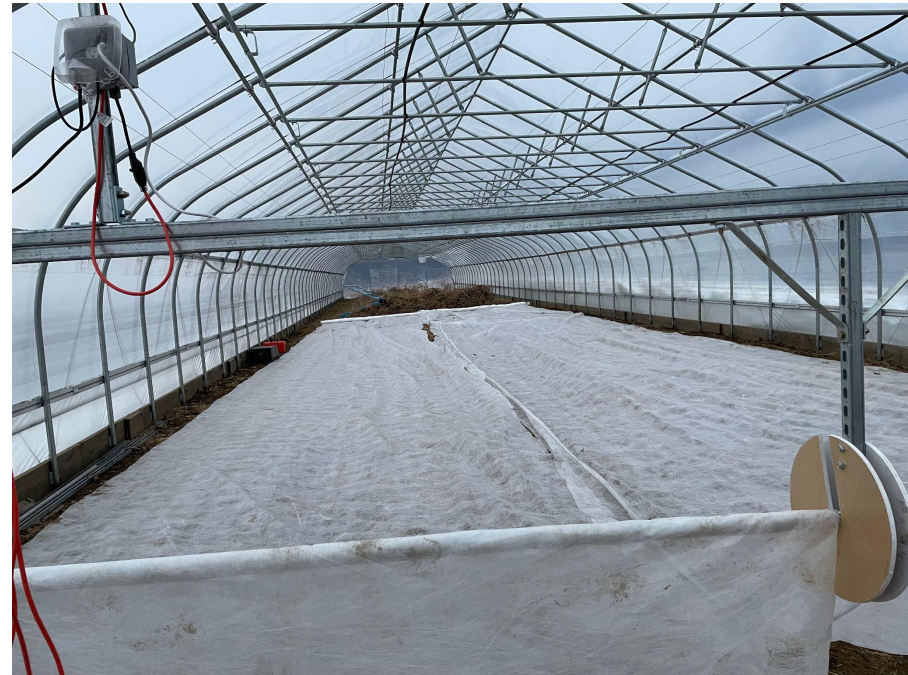

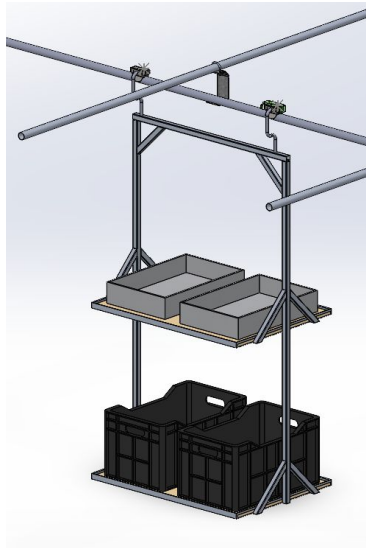

ITEM NO.	QTY.	DESCRIPTION	LENGTH
1	4	L 1.00 X 1.00 X .125	16
2	2	1" x 1" Square Tubing	86
3	1	1" x 1" Square Tubing	18
4	4	1" x 1" Square Tubing	10.6066
5	6	1" x 1" Square Tubing	11.3137
6	4	L 1.00 X 1.00 X .125	40
7	1	1" x 1" Square Tubing	36
8	4	1" x 1" Square Tubing	11.6066

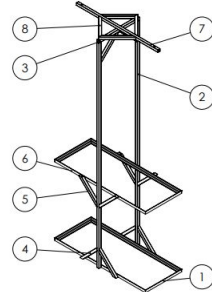

Preliminary Design

Concept of operations and major components.

Critical Design

System engineering and development roadmap.

Development

Procure & build.

Iteration, Testing, Evaluation

Testing, prototyping, additional design implementation.

Gantry Basics

Rail System - Overview

The Rail System is the track for the gantry system. The rails are placed above the rows in the high tunnel, allowing the passage of tooling throughout the season. Gantry tools use the rails for transportation throughout the high tunnel. The rails are made from round pipe used for fence top rails and hung with U-bolt hangers. Rails are connected by swaged fittings and screws.

Subsystems

- Rail - Round tube that creates a track for the gantry system.
- Hangers - U shaped hanger to support the rail and allow trolley passage.
- Rail Connections - Swaged ends plus screws.

Hanger



Rail Connector



Rail





Toolbar - Frame

The Toolbar Frame is designed to hang from Trolleys on the Rail System. The Frame will include rigid bars from the Trolleys to a spanning bar for Tooling Attachments. The Frame must support the ARCS load weight and torque applied during spooling operations.

Functions

- Trolley Attachment Point - Unistrut Bar with holes for trolley pin and fastener connection.
- Vertical Hanging Bar - Vertical bars to lower toolbar from Rail System.
- Horizontal Toolbar - Primary toolbar with Unistrut for Tooling Attachments.
- Truss System - Support structure for the Horizontal Toolbar.

Key Requirements

- Load: 300 lbf

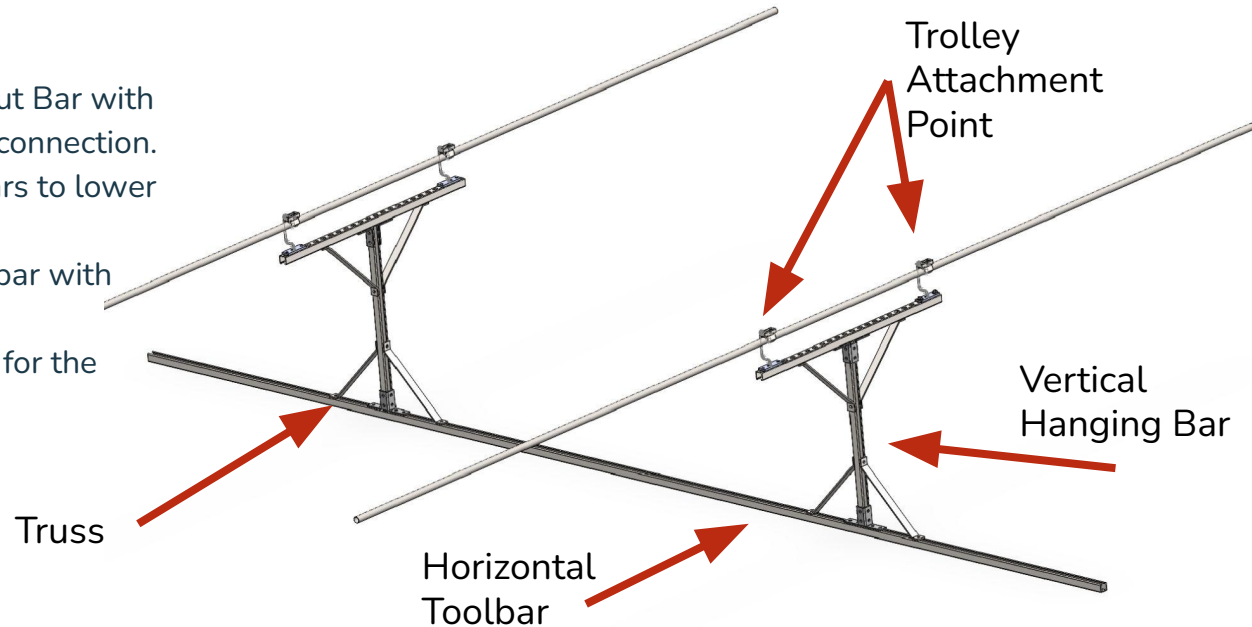

Transport Cart

Design

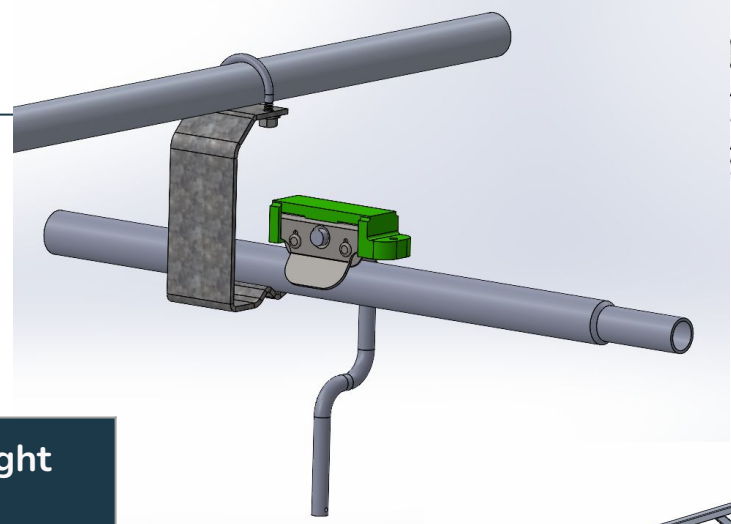

Tray Name	Tray Size	Cart Capacity	Stack Size	Weight
10# Tomato Cartons	13"x20"x3.75"	24	6	240 lbs
15# Tomato Cartons	16"x23.5"x4.5"	16	4	240 lbs
Bread Tray	25"x21.5"x4.5"	8	4	200 lbs
Stackable Crate	23.75"x18"x11.5"	6	1, 2	210 lbs

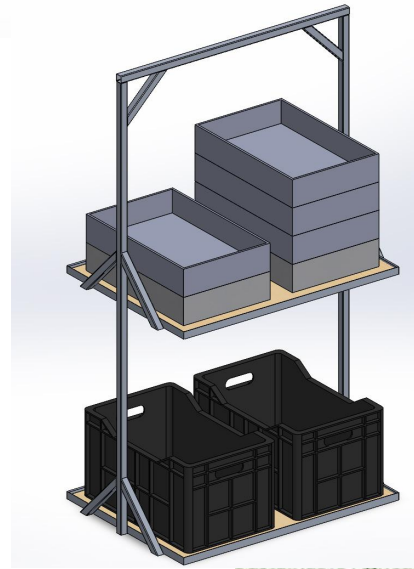

Development

- Send cart frame drawings to local fabrication shop, paint frame
- Purchase and trim plywood shelves
- Attach trolleys



Labor Study

Recorded 15 harvests of cherry tomatoes in a 96' high tunnel, Aug - Sept '23

Harvest	Sessions	Total Weight (lbs)	Average Harvest Weight (lbs)	Total Harvest Time (hours)	Average Pounds per hour	Total bed length (ft)	Average ft per hour
Test	6	1,095.7	182.6	6.9	158.8	537	77.8
Control	4	979.8	108.9	5.1	136.6	346	67.8

Farmers recorded the following benefits by using the cart:

+22
lbs / hour

+10
bed feet / hour

\$714
Labor savings /
month / row

Investment & Return

Component	Price
Cart Fabrication	\$594
SS20 Pipe	\$580
Railex Rail Supports	\$370
Railex Trolleys	\$80
Consumables	\$50
Total	\$1,674

For 96' Tunnel

- \$714 labor savings per month
- Assuming 3-month harvest period per tunnel, \$2,142 annual labor savings
- Total investment \$1,674
- Payback period of .78 years

Automated Row Cover System

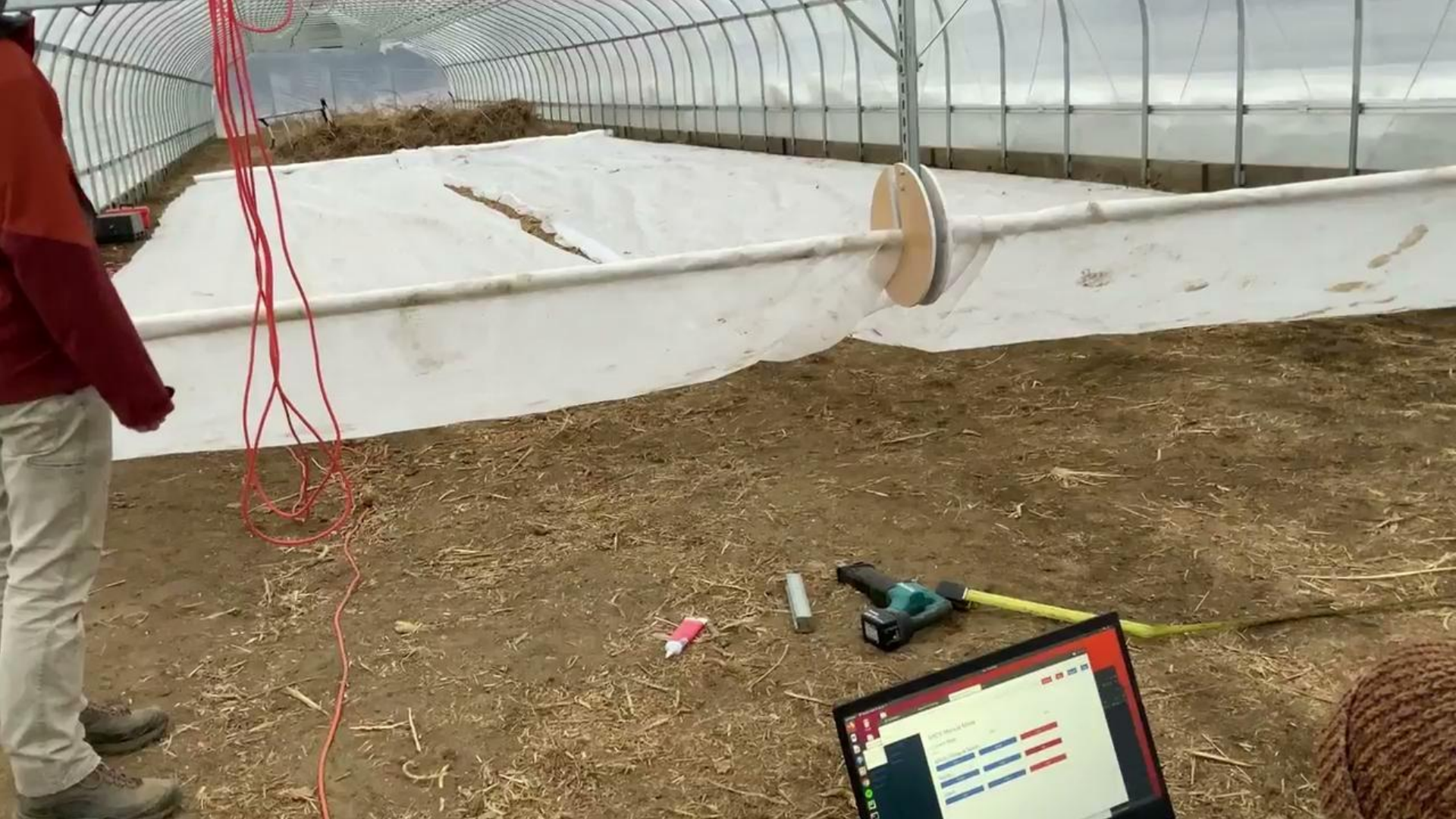

2023 Week 10		
Category	Value	Value
Category 1	Value 1	Value 2
Category 2	Value 1	Value 2
Category 3	Value 1	Value 2
Category 4	Value 1	Value 2
Category 5	Value 1	Value 2
Category 6	Value 1	Value 2
Category 7	Value 1	Value 2
Category 8	Value 1	Value 2
Category 9	Value 1	Value 2
Category 10	Value 1	Value 2

ARCS - Overview

The Automatic Row Cover System (ARCS) is designed to automatically spool row cover. The system will span the width of the high tunnel and will attach to the toolbar. The Trolley Car will automatically move the system down the high tunnel during spooling operations. The ARCS will include spooling motors and control system to automatically manage row cover.

Subsystems

- Frame
- Spool Drive System
- Motor Module
- ARCS Controller
- ARCS User Interface

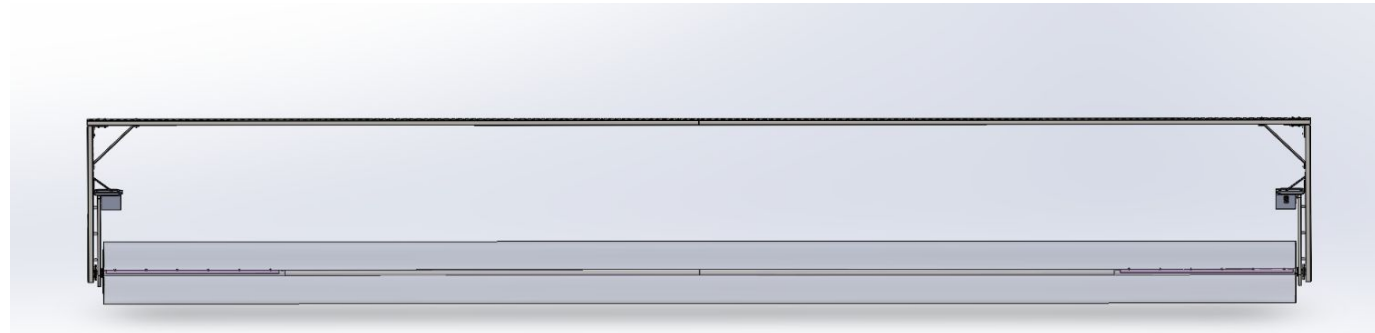

ARCS - Frame

The ARCS frame will attach to the Toolbar. The frame will provide support and mounting for the main spool and row cover spooling system. The spool must span the distance of the high tunnel, maximizing wall to wall coverage. The width of the frame is dictated by the width of the high tunnel at the height of the toolbar. To maximize potential width, we narrowed the height of the ARCS frame and lowered the toolbar.

Functions

- Toolbar Attachment - Attachment from the ARCS Frame to the Toolbar.
- Main Spool Mounting - Structure and bearing to support a fully loaded spool.
- Drive System Mounting - Mounting for the motors and drive system.
- Spool - Shaft to load row cover.



ARCS - Row Cover Roll

- Remy size 30' x 100'
- Targeting 27'10" (down from 28'6") wide remay on the roll
- Typar T-518 Row Cover
- PVC clip to attach to bar

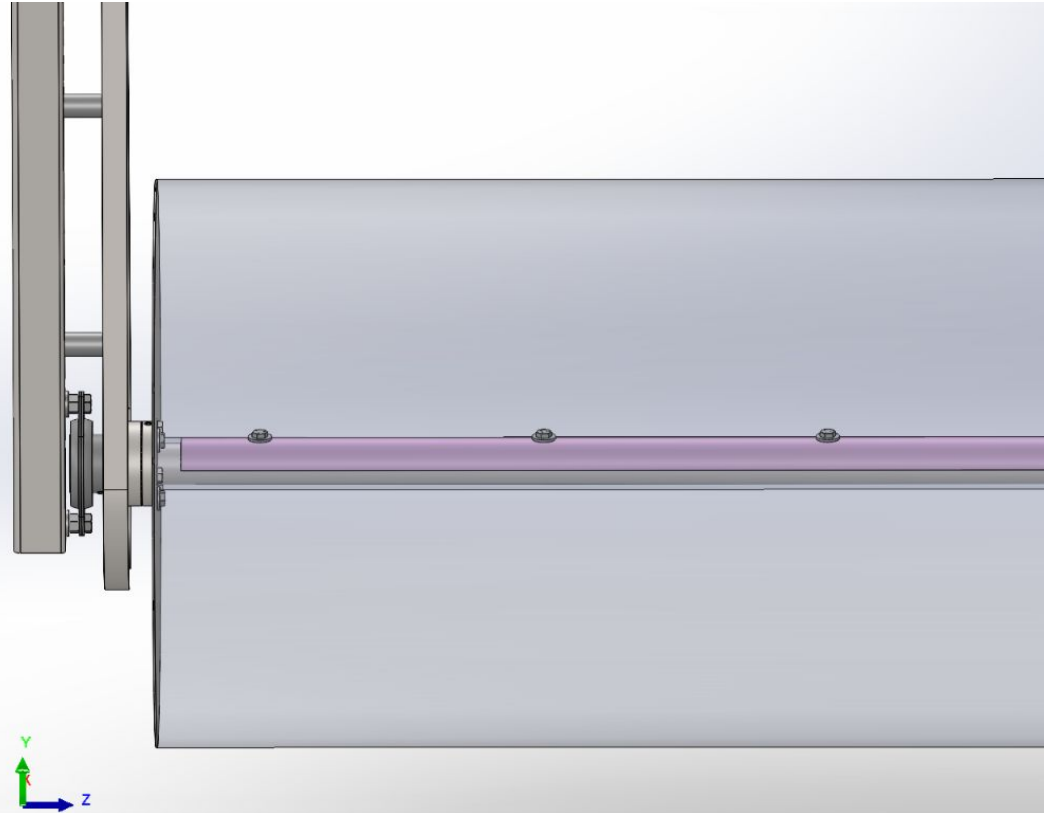

ARCS - Spool Drive System

The Row Cover Spooling System is the main drive mechanism for spooling row cover. The spooling system includes drive motors to rotate the spool in both directions. The drive mechanism transfers rotational power from the motors to the main spool.

Functions

- Spooling Motors - Two motor modules to drive both sides of the spool.
- Drive Mechanism - Sprocket and chains to drive the spool.

Key Requirements

- NEMA 23 Motor Module - Utilize the components from Trolley Car.

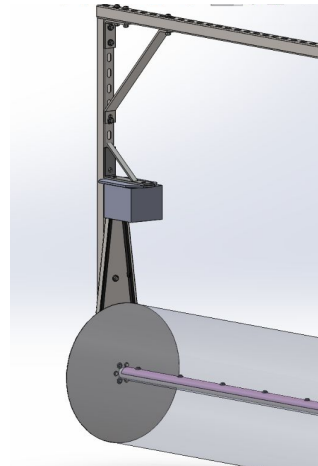

Trolley Car - Overview

The Trolley Car is a motorized trolley that connects to the toolbar and moves implements on the Rail System. The Trolley Car has one drive wheel connected to a drive motor to move the trolley down the rail. The system will calculate the position of the Trolley car along the track using motor position feedback. An internal control system will manage the movement and process external motion commands. Trolley Cars can operate independently or together in coordinated motions. A bottom facing camera will record crop imagery and provide situational awareness for operators.

Subsystems

- Enclosure
- Hitch
- Traction System
- Drive System
- Trolley Control System
- Vision System

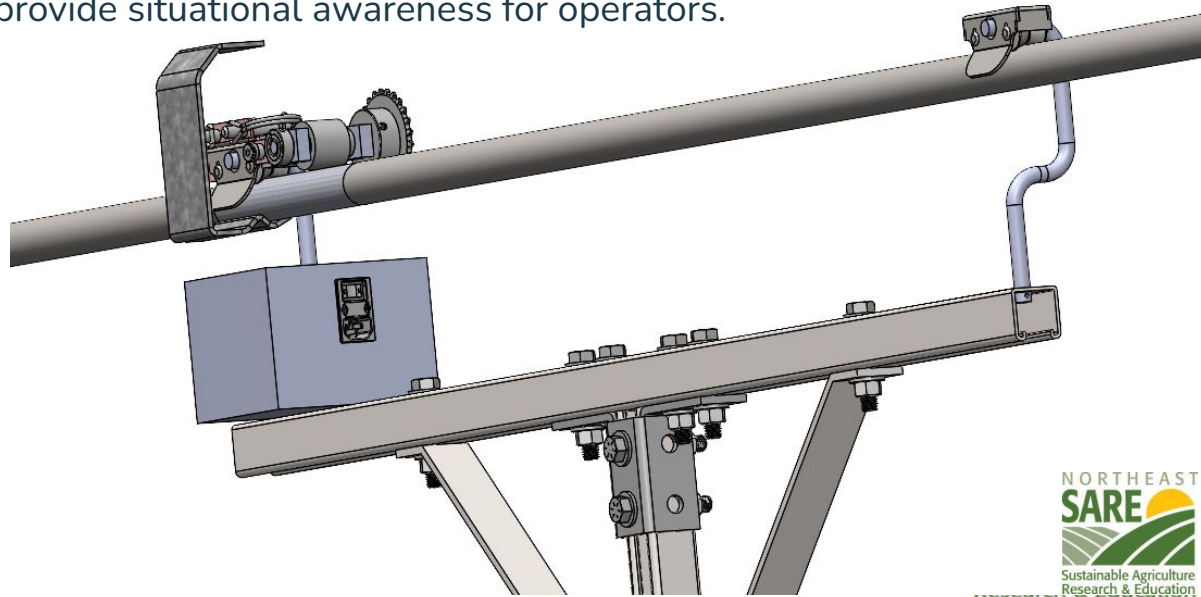

Trolley Car - Traction System

The Traction System converts the motors rotational motion into linear motion along the rail.

The weight of the toolbar and implements are the normal force applied to the wheel for traction along the rail. The drive wheel is attached by a drive shaft and chain & sprocket to the motor.

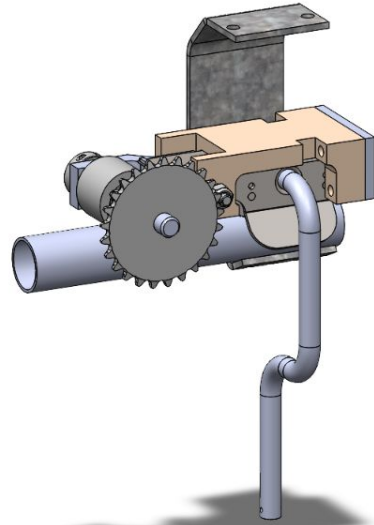

Development (V2)

- 30' span is too long for spooling motors.
- Trolley loses traction and “pops” off of the rail. Increasingly problematic as the temperatures increase.
 - Redesign the trolley.
- Spooling motor underpowered to drive the bar “uphill” from its sag. Increasingly problematic when the ARCS has been sitting for extended periods of time.
 - Redesign the row cover drive assembly and add gearbox for more torque.

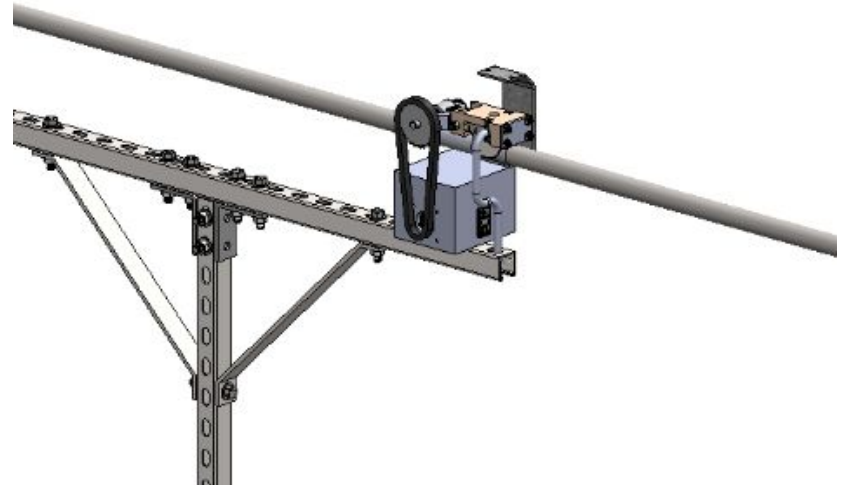



Trolley Car

Redesigned Trolley Car uses the weight of the toolbar to increase friction on drive rollers. Drive Rollers will be put on lathe to feature v-groove for guidance on greenhouse piping.

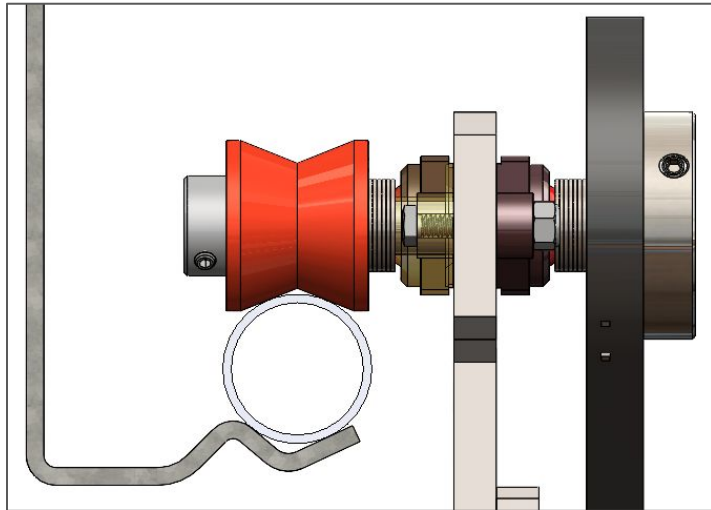

Toolbar
hang
point

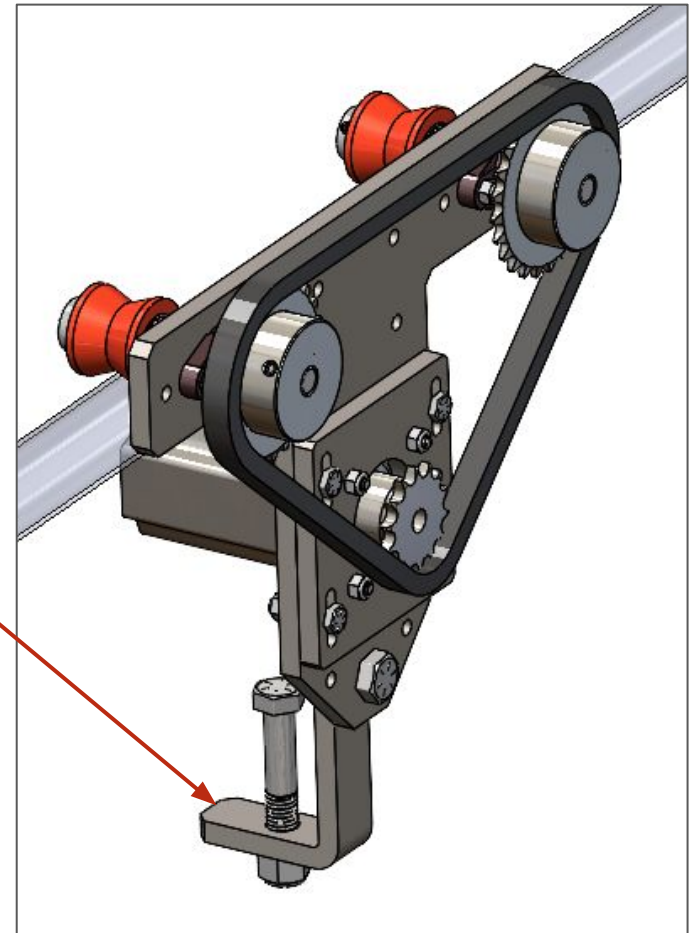

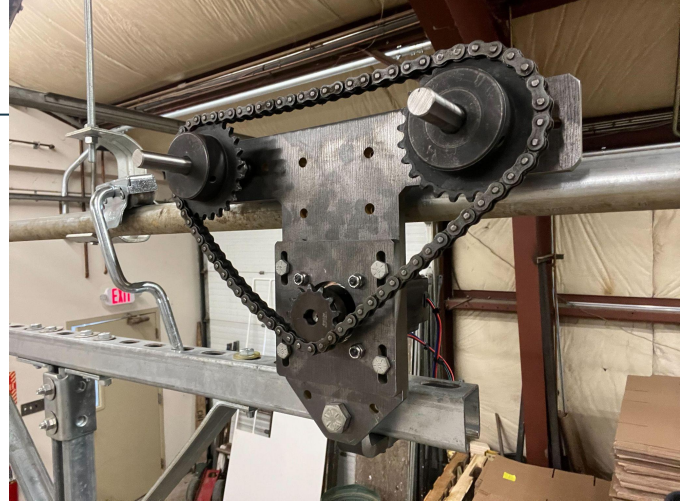

Row Cover Drive Assembly

Motor Mount allow adjustability in:

- Vertical dimension for chain tensioning
- Tilt, to properly align chain “in plane” with drive sprocket of row cover spool
- In out dimension to bring drive chain in plane with row cover sprocket.

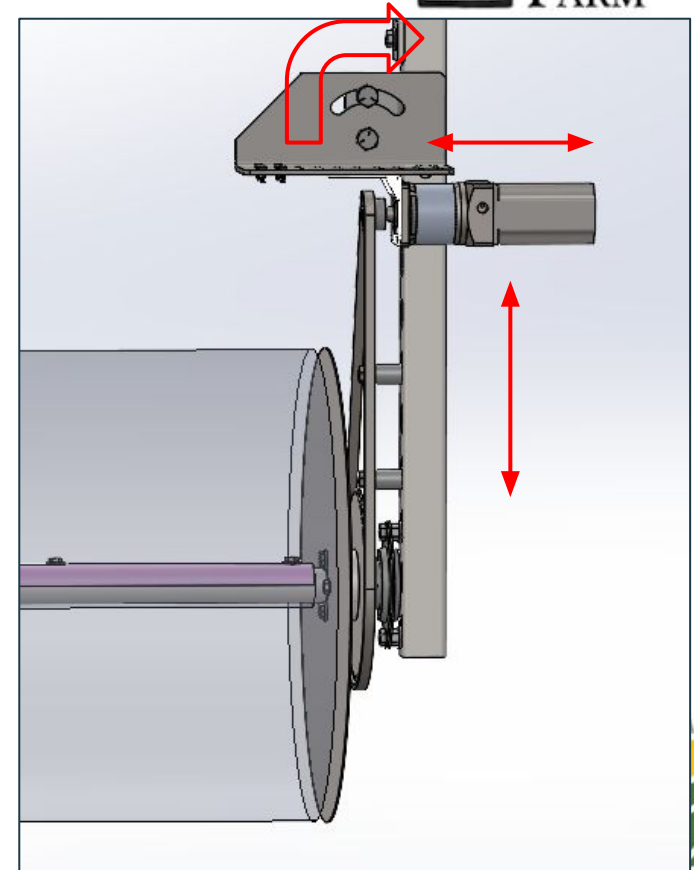
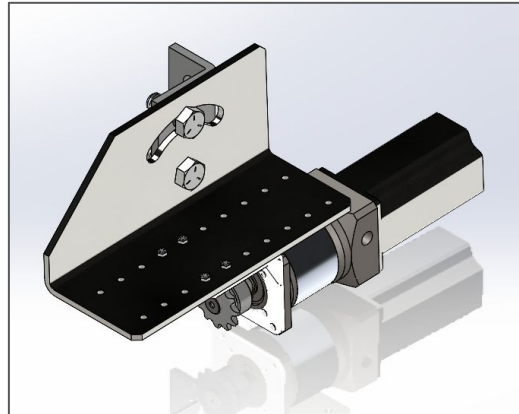





Recommendations for Further Study

- Attempt hanging 2 ARCSs in the same tunnel, each covering half of the house.
 - Increases the price and complexity.
 - Decreases rolling issues.
 - Covers center and side strips.
- Top Rail SS20 with 4' hangers
 - 8' suffices for Transport Cart
 - 4' will reduce sag in pipe which will increase motor performance and traction
- Run at slow speeds.
 - 15-20 minutes to cover or uncover.
- Build a different implement.
 - Farmers are interested in automation, but have found other solutions to managing row cover.
 - Farmers interviewed were more interested in other applications, such as boom watering or weeding.

Thank you